

Electrical Measurement & Instrumentation

Semester-4th

CONTENTS

- Measuring instruments
- Analog ammeters and voltmeters
- Wattmeter and measurement of power
- Energy meters and measurement of energy
- Measurement of speed, frequency and power factor
- Measurement of Resistance, Inductance & Capacitance
- Sensors And Transducer
- Oscilloscope

CHAPTER-1

MEASURING INSTRUMENTS

1. **ACCURACY**- The closeness with which an instrument reading approaches the true value of the quantity being measured is called accuracy. Accuracy is determined as the maximum amount by which the result differs from the true value.
2. **PRECISION**- The term precise means means clearly or sharply defined. Precision is a measure of reproducibility of measurement.
3. **ERRORS**- The deviation or change of the value obtained from measurement from the desired standard value.

Mathematically,

$$\text{Error} = \text{Obtained Reading/Value} - \text{Standard Reference Value.}$$

There are three types of error. They are as follows:-

GROSS ERRORS-This are the error due to humans mistakes such as careless reading mistakes in recoding observation incorrect application of an instrument.

SYSTEMATIC ERROR-A constant uniform deviation of an instrument is as systematic error. There are two types of systematic error.

a) **STATIC ERROR**

The static error of a measuring instrument is the numerical different between the true value of a quantity and its value as obtained by measurement.

b) **DYNAMIC ERROR**-

1. It is the different between true value of a quantity changing with and value indicated by the instrument.
2. The Dynamic Errors are caused by the instrument not responding fast enough to follow the changes in the measured value.

RANDOM ERROR-The cause of such error is unknown or not determined in the ordinary process of making measurement.

TYPES OF STATIC ERROR

1. **INSTRUMENTAL ERROR**- Instrumental error are errors inherent in mastering

instrument because of the mechanical construction friction is bearing in various moving component. It can be avoided by

- a. Selecting a suitable instrument for the particular measurement.
- b. Applying correction factor after determining the amount of instrumental error.

2. ENVIRONMENTAL ERROR –Environmental error are due to conditions external to the measuring device including condition al in the area surrounding the instrument such as effect of change in temperature , humidity or electrostatic field it can be avoided

- a. Providing air conditioning.
- b. Use of magnetic shields.

3. OBSERVATIONAL ERROR- The errors introduced by the observer. These errors are caused by habits of the observers like tilting his/her head too much while reading a “Needle – Scale Reading”.

Measuring instruments are classified according to both the quantity measured by the instrument and the principle of operation.

There are three general principles of operation:

- electromagnetic, which utilizes the magnetic effects of electric currents;
- electrostatic, which utilizes the forces between electrically-charged conductors;
- Electro-thermic, which utilizes the heating effect

Electric measuring instruments and meters are used to indicate directly the value of current, voltage, power or energy. An electromechanical meter (input is as an electrical signal results mechanical force or torque as an output) that can be connected with additional suitable components in order to act as anammeters and a voltmeter. The most common analogue instrument or meter is the permanent magnet moving coil instrument and it is used for measuring a dc current or voltage of an electric circuit.

4. SENSITIVITY- Sensitivity can be defined as a ratio of a change output to the change input at steady state condition.

5. RESOLUTION- Resolutions the least increment value of input or output that can be detected, caused or otherwise discriminated by the measuring device.

6. TOLERANCE- Tolerance refers to the total allowable error within an item. This is typically represented as a +/- value off of a nominal specification. Products can become deformed due to changes in temperature and humidity, which lead to material expansion and contraction, or due to improper feedback from a process control device. As such, it's necessary to take errors into consideration with regard to design values in the manufacturing

and inspection processes.

CLASSIFICATION OF MEASURING INSTRUMENT-

The instrument may be classified as

1. Absolute and secondary Instrument
2. Analog and digital Instrument
3. Mechanical, Electrical and Electronics Instruments.
4. Manual and automatic instruments
5. Self contained and remote indicating instruments
6. Self operated and power-operated instrument
7. Deflection and Null output instrument.

1. Absolute instrument & Secondary instruments:

Absolute instrument measures the process variable directly from the process without the use of conversion. Such instruments do not require comparison with any other standard. The tangent galvanometer is an example for the absolute instrument. These instruments are used as standards in labs and institution.

Secondary instrument: These instruments are so constructed that the deflection of such instruments gives the magnitude of the electrical quantity to be measured directly. These instruments required to calibrated with respect to the standard instrument. These instruments are usually used in practice.

Secondary instruments are classified as:

1. Indicating instrument: Those instruments that measure and indicates the magnitude of the electricity. The indications are given by a pointer moving over a calibrated scale. Ordinary ammeters, voltmeters, wattmeters, frequency meters, power factor meters, etc., fall into this category.
2. Integrating instrument: Integrating instruments are those which measure the total amount of either quantity of electricity (ampere-hours) or electrical energy supplied over a period of time. The ampere-hour meters and energy meters fall in this class.
3. Recording instrument: These instruments record continuously the variation of the magnitude of the electric quantity for a definite period of time. Such instruments are generally used in powerhouses where the current, voltage, power, etc., are to be maintained within a certain acceptable limit.

2. Analog and digital Instrument

Analog instrument: The signals of an analog unit vary in a continuous fashion and can take on an infinite number of values in a given range. Fuel gauge, ammeter and voltmeters, wristwatch, speedometer fall in this category.

Digital Instruments: Signals that vary in discrete steps and that take a finite number of different values in a given range are digital signals and the corresponding instruments are of digital type. Digital instruments have some advantages over analog meters, in that they have high accuracy and high speed of operation. Digital multimeter is an example for the digital instrument.

3. Mechanical, Electrical and Electronics Instruments.

Mechanical instrument: Mechanical instruments are very reliable for static and stable conditions. As they use mechanical parts these instruments cannot faithfully follow the rapid changes which are involved in dynamic instruments. But they are cheaper in cost and durable.

Electrical Instruments: When the instrument pointer deflection is caused by the action of some electrical methods then it is called an electrical instrument. The time of operation of an electrical instrument is more rapid than that of a mechanical instrument. This mechanical movement has some inertia due to which the frequency response of these instruments is poor.

Electronic Instruments: Electronic instruments use semiconductor devices. They are very fast in response. In electronic devices, since the only movement involved is that of electrons, the response time is extremely small owing to very small inertia of the electrons. With the use of electronic devices, a very weak signal can be detected by using pre-amplifiers and amplifiers.

4. Manual and automatic instruments

In case of **Manual instruments** services of an operator are required. Example: Measurement of temperature by a resistance thermometer incorporating a Wheatstone bridge in its circuit.

In an **Automatic Instrument** an operator is not required. Example: Measurement of temperature by mercury-in-glass thermometer.

5. Self contained and remote indicating instruments

A **Self contained instrument** has all its different elements in one physical assembly.

In a **Remote Indicating Instrument** the primary sensing element may be located at an adequate long distance from the secondary indicating element. Such type of instrument are finding wide use in the modern instrumentation technology.

6. Self operated and power-operated instrument

Self-operated instruments don't need any outside power for its working. The output energy is supplied wholly or almost wholly by the input measurand. Dial indicating type instruments belong to this category.

Power operated instrument need external power for its working. External power can electric current, hydraulic or pneumatic energy. In such cases, the input signal supplies only an insignificant portion of the output power.

7. Deflection and Null output instrument.

In a **deflection-type instrument**, the deflection of the instrument indicates the measurement of the unknown quantity. The measurand quantity produces some physical effect which deflects or produces a mechanical displacement in the moving system of the instrument.

An opposite effect is built in the instrument which opposes the deflection or the mechanical displacement of the moving system. The balance is achieved when opposing effect equals the actuating cause producing the deflection or the mechanical displacement. Permanent Magnet Moving Coil (PMMC), Moving Iron (MI), etc., type instruments are examples of this category.

In **Null type instruments**, a zero or null indication leads to the determination of the magnitude of the measurand quantity. The null condition depends upon some other known conditions. These are more accurate and highly sensitive as compared to deflection-type instruments. A dc potentiometer is a null- type instrument.

TYPES OF FORCES/TORQUES ACTING IN MEASURING INSTRUMENTS

1. DEFLECTING TORQUE/FORCE:

The deflection of any instrument is determined by the combined effect of the deflecting torque/force, control torque/force and damping torque/force. The value of deflecting torque must depend on the electrical signal to be measured. This torque/force causes the instrument movement to rotate from its zero position.

MAGNITUDE EFFECT

When a current passes through the coil, it produces an imaginary bar magnet. When a soft-iron piece is brought near this coil it is magnetized. Depending upon the current direction the poles are produced in such a way that there will be a force of attraction between the coil and the soft iron piece. This principle is used in moving iron attraction type instrument.

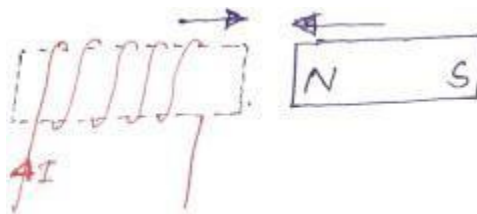

If two soft iron pieces are placed near a current-carrying coil, there will be a force of repulsion.

between the two soft iron pieces. This principle is utilized in the moving iron repulsion type instrument.

FORCE BETWEEN A PERMANENT MAGNET AND A CURRENT CARRYING COIL

When a current carrying coil is placed under the influence of magnetic field produced by a permanent magnet and a force is produced between them. This principle is utilized in the moving coil type instrument.

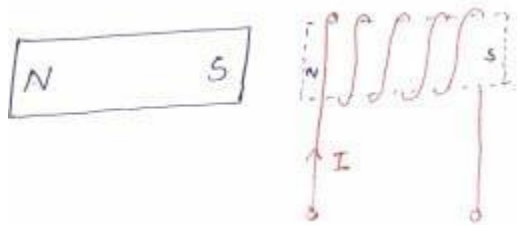

FORCE BETWEEN TWO CURRENT CARRYING COIL

When two current carrying coils are placed closer to each other there will be a force of repulsion between them. If one coil is movable and other is fixed, the movable coil will move away from the fixed one. This principle is utilized in electro-dynamometer type instrument.

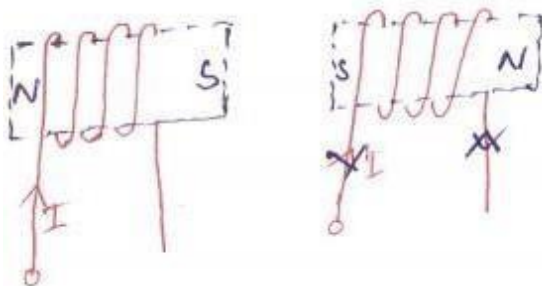

2. CONTROLLING TORQUE/FORCE:

This torque/force must act in the opposite sense to the deflecting torque/force, and the movement will take up an equilibrium or definite position when the deflecting and controlling torque are equal in magnitude. The Spiral springs or gravity usually provides the controlling torque.

When the external signal to be measured by the instrument is removed, the pointer should return back to the zero position. This is possibly due to the controlling force and the pointer will be indicating a steady value when the deflecting torque is equal to controlling torque.

$$T_d = T_c$$

SPRING CONTROL

Two springs are attached on either end of spindle. The spindle is placed in jewelled bearing, so that the frictional force between the pivot and spindle will be minimum. Two springs are provided in opposite direction to compensate the temperature error. The spring is made of phosphorous bronze. When a current is supply, the pointer deflects due to rotation of the spindle. While spindle is rotate, the spring attached with the spindle will oppose the movements of the pointer. The torque produced by the spring is directly proportional to the pointer deflection θ .

$$T_c \propto \theta$$

The deflecting torque produced T_d proportional to 'I'. When $T_C = T_d$, the pointer will come to a steady position. Therefore

$$\theta \propto I$$

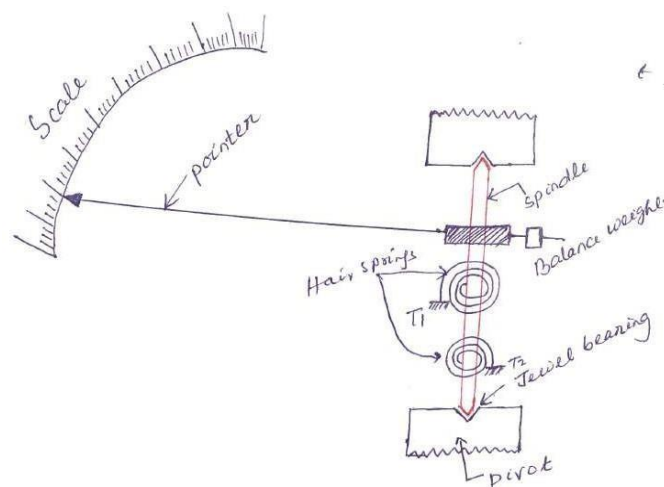

3. DAMPING TORQUE/FORCE:

A damping force is required to act in a direction opposite to the movement of the moving system. This brings the moving system to rest at the deflected position reasonably quickly without any oscillation or very small oscillation.

To damp out the oscillation as quickly as possible, a damping force is necessary.

This force is produced by different systems.

- (a) Air friction damping
- (b) Fluid friction damping
- (c) Eddy current damping

CHAPTER- II

ANALOG AMMETERS & VOLTMETERS

PERMANENT MAGNET MOVING COIL (PMMC) INSTRUMENT

One of the most accurate type of instrument used for D.C. measurements is PMMC instrument.

CONSTRUCTION:

The moving coil and permanent magnet are the main part of the PMMC instrument. The parts of the PMMC instruments are explained below in details.

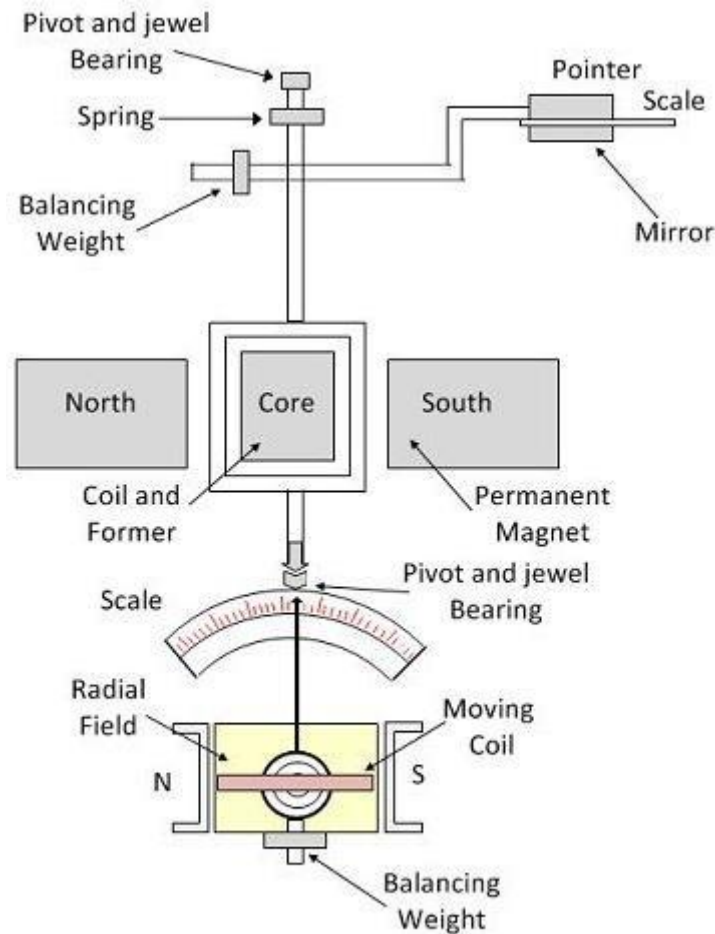

Permanent Magnet Moving Coil Instrument

Moving Coil – The coil is the current carrying part of the instruments which is freely moved between the stationary field of the permanent magnet. The current passes through the coil deflects it due to which the magnitude of the current or voltage is determined. The coil is mounted on the rectangular former which is made up of aluminium. The former increases the radial and uniform

magnetic field between the air gaps of the poles. The coil is wound with the silk cover copper wire between the poles of a magnet.

The coil is mounted on the rectangular former which is made up of aluminium. The former increases the radial and uniform magnetic field between the air gaps of the poles. The coil is wound with the silk cover copper wire between the poles of a magnet.

Magnet System – The PMMC instrument using the permanent magnet for creating the stationary magnets. The Alcomax and Alnico material are used for creating the permanent magnet because this magnet has the high coercive force (The coercive force changes the magnetisation property of the magnet). Also, the magnet has high field intensities.

Control – In PMMC instrument the controlling torque is because of the springs. The springs are made up of phosphorous bronze and placed between the two jewel bearings. The spring also provides the path to the lead current to flow in and out of the moving coil. The controlling torque is mainly because of the suspension of the ribbon.

Damping – The damping torque is used for keeping the movement of the coil in rest. This damping torque is induced because of the movement of the aluminium core which is moving between the poles of the permanent magnet.

Pointer & Scale – The pointer is linked with the moving coil. The pointer notices the deflection of the coil, and the magnitude of their deviation is shown on the scale. The pointer is made of the lightweight material, and hence it is easily deflected with the movement of the coil. Sometimes the parallax error occurs in the instrument which is easily reduced by correctly aligning the blade of the pointer.

PRINCIPLE OF OPERATION

When D.C. supply is given to the moving coil, D.C. current flows through it. When the current carrying coil is kept in the magnetic field, it experiences a force. This force produces a torque and the former rotates. The pointer is attached with the spindle. When the former rotates, the pointer moves over the calibrated scale. When the polarity is reversed a torque is produced in the opposite direction. The mechanical stopper does not allow the deflection in the opposite direction. Therefore the polarity should be maintained with PMMC instrument. If A.C. is supplied, a reversing torque is produced. This cannot produce a continuous deflection. Therefore this instrument cannot be used in A.C.

TORQUE DEVELOPED BY PMMC

The deflecting torque induces because of the movement of the coil. The deflecting torque is expressed by the equation shown below.

$$T_d = NBLdl \dots \text{equ}(1)$$

Where, I- Current through the coil,

N – Number of turns of coil

B – flux density in the air gap

L, d – the vertical and horizontal length of the side

$$G = NBLd \dots \text{equ}(2)$$

The spring provides the restoring torque to the moving coil which is expressed as

$$T_c = K\theta \dots \text{equ}(3)$$

Where K = Spring constant.

For final deflection, $T_c = T_d$

By substituting the value of equation (1) and (3) we get,

$$K\theta = GI$$

$$\theta = \frac{GI}{K} \dots \text{equ}(4)$$

$$I = \frac{K}{G}\theta \dots \text{equ}(5)$$

The above equation shows that the deflection torque is directly proportional to the current passing through the coil.

ERRORS IN PMMC INSTRUMENT:

In PMMC instruments the error occurs because of the ageing and the temperature effects of the instruments. The magnet, spring and the moving coil are the main parts of the instruments which cause the error. The different types of errors of the instrument are explained below in details.

1. Magnet – The heat and vibration reduce the lifespan of the permanent magnet. This treatment also reduced the magnetism of the magnet. The magnetism is the property of the attraction or repulsion of the magnet. The weakness of the magnet decreases the deflection of the coil.

2. Springs – The weakness of the spring increases the deflection of moving coil between the permanent magnet. So, even for the small value of current, the coil show large deflection. The spring gets weakened because of the effect of the temperature. One degree rise in temperature reduces the 0.004 percent life of the spring.

3. Moving Coil – The error exists in the coil when their range is extended from the given limit by the use of the shunt. The error occurs because of the change of the coil resistance on the shunt resistance. This happens because the coil is made up of copper wire which has high shunt resistance and the shunt wire made up of Magnin has low resistance.

To overcome from this error, the swamping resistance is placed in series with the moving coil. The resistor which has low-temperature coefficient is known as the swamping resistance. The swamping resistance reduces the effect of temperature on the moving coil.

Advantages of PMMC Instruments

The following are the advantages of the PMMC Instruments.

1. The scale of the PMMC instruments is correctly divided.
2. The power consumption of the devices is very less.
3. The PMMC instruments have high accuracy because of the high torque weight ratio.
4. The single device measures the different range of voltage and current. This can be done by the use of multipliers and shunts.
5. The PMMC instruments use shelf shielding magnet which is useful for the aerospace applications.

Disadvantages of PMMC Instruments

The following are the disadvantages of the PMMC instruments.

1. The PMMC instruments are only used for the direct current. The alternating current varies with the time. The rapid variation of the current varies the torque of the coil. But the pointer can not follow the fast reversal and the deflection of the torque. Thus, it cannot use for AC.
2. The cost of the PPMC instruments is much higher as compared to the moving coil instruments.

The moving coil itself provides the electromagnetic damping. The electromagnetic damping opposes the motion of the coil which is because of the reaction of the eddy current and the magnetic field.

RANGES OF PMMC INSTRUMENT:

DC ammeter:

1. Without shunt- 0/5 micro amperes upto 0/30 microamperes
2. With internal Shunt- upto 0/2000 amperes
3. With external Shunt- upto 0/5000 amperes

DC Voltmeters:

1. Without series resistance- 0/100 milli-volts
2. With series resistance- upto 0/5000 amperes

MOVING IRON (MI) INSTRUMENTS

One of the most accurate instruments used for both AC and DC measurement is moving iron instrument. There are two types of moving iron instrument.

- Attraction type
- Repulsion type

ATTRACTION TYPE M.I. INSTRUMENT

CONSTRUCTION:

It consists of a flat cylindrical coil. The moving iron is a flat disc or oval shaped disc, pivoted on a spindle. A pointer is attached to the spindle which moves on a calibrated scale. The controlling force is obtained by gravity control system. The damping force is provided by air friction with the help of light aluminium piston attached to the moving system

PRINCIPLE OF OPERATION

The current to be measured is passed through the fixed coil. As the current is low through the fixed coil, a magnetic field is produced. By magnetic induction the moving iron gets magnetized. The north pole of moving coil is attracted by the south pole of fixed coil. Thus the deflecting force is produced due to force of attraction. Since the moving iron is attached with the spindle, the spindle rotates and the pointer moves over the calibrated scale. But the force of attraction depends on the current flowing through the coil.

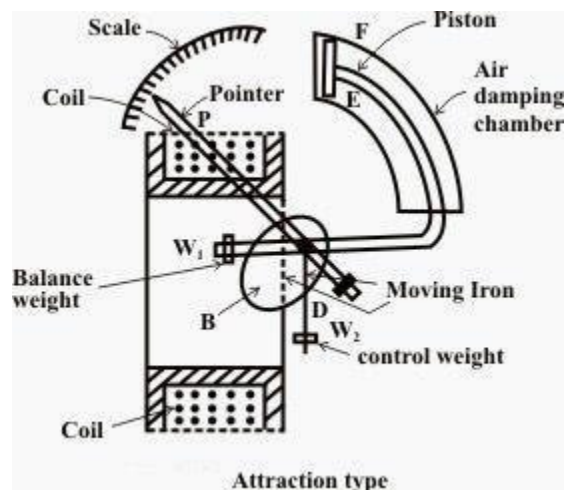

REPULSION TYPE MOVING IRON INSTRUMENT

CONSTRUCTION:

The repulsion type instrument has a hollow fixed iron attached to it . The moving iron is connected to the spindle. The pointer is also attached to the spindle in supported with jeweled bearing.

PRINCIPLE OF OPERATION:

When the current flows through the coil, a magnetic field is produced by it. So both fixed iron and moving iron are magnetized with the same polarity, since they are kept in the same magnetic field. Similar poles of fixed and moving iron get repelled. Thus the deflecting torque is produced due to magnetic repulsion. Since moving iron is attached to spindle, the spindle will move. So that pointer moves over the calibrated scale. Damping: Air friction damping is used to reduce the oscillation. Control: Spring control is used.

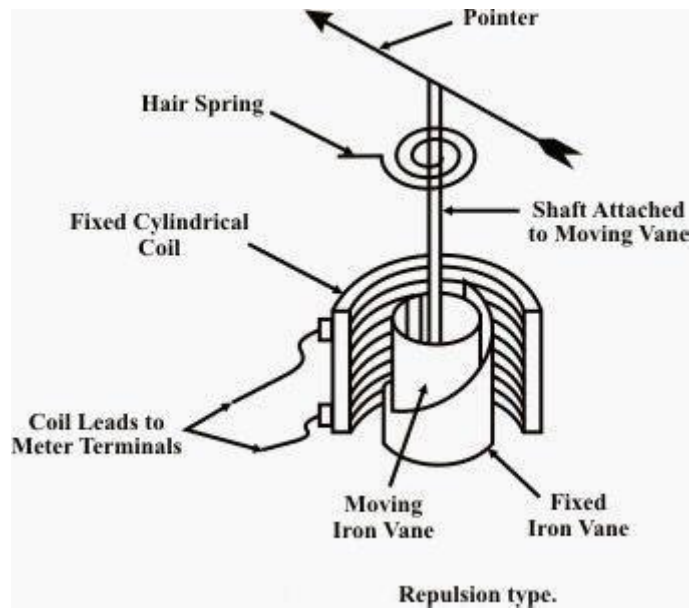

Ranges of Ammeter and Voltmeter

1. For a given moving-iron instrument the ampere-turns necessary to produce full-scale deflection are constant.
2. One can alter the range of ammeters by providing a shunt coil with the moving coil.
3. Voltmeter range may be altered connecting a resistance in series with the coil. Hence the same coil winding specification may be employed for a number of ranges.

Advantages

1. The instruments are suitable for use in AC and DC circuits.
2. The instruments are robust, owing to the simple construction of the moving parts.
3. The stationary parts of the instruments are also simple.
4. Instrument is low cost compared to moving coil instrument.
5. Torque/weight ratio is high, thus less frictional error.

Disadvantages

1. Scale not uniform.
2. For low voltage range, the power consumption is higher.
3. The errors are caused due to hysteresis in the iron of the operating system and due to stray magnetic field.
4. In case of AC measurements, change in frequency causes serious error.
5. With the increase in temperature the stiffness of the spring decreases.

Errors

- Error due to variation in temperature.
- Error due to friction is quite small as torque-weight ratio is high in moving coil instruments.
- Stray fields cause relatively low values of magnetizing force produced by the coil. Efficient magnetic screening is essential to reduce this effect.
- Error due to variation of frequency causes change of reactance of the coil and also changes the eddy currents induced in neighbouring metal.
- Deflecting torque is not exactly proportional to the square of the current due to non-linear characteristics of iron material.

DYNAMOMETER (OR) ELECTROMAGNETIC MOVING COIL INSTRUMENT

Dynamometer type measuring instruments are similar to PMMC instrument. Except that the permanent magnetic field coil is replaced by a coil which carries the current to be measured. They have precision grade accuracy both for ac and dc measurements

CONSTRUCTION:

A fixed coil is divided in to two equal half. The moving coil is placed between the two half of the fixed coil. Both the fixed and moving coils are air cored. So that the hysteresis effect will be zero. The pointer is attached with the spindle. In a non metallic former the moving coil is wounded.

Control: Spring control is used.

Damping: Air friction damping is used.

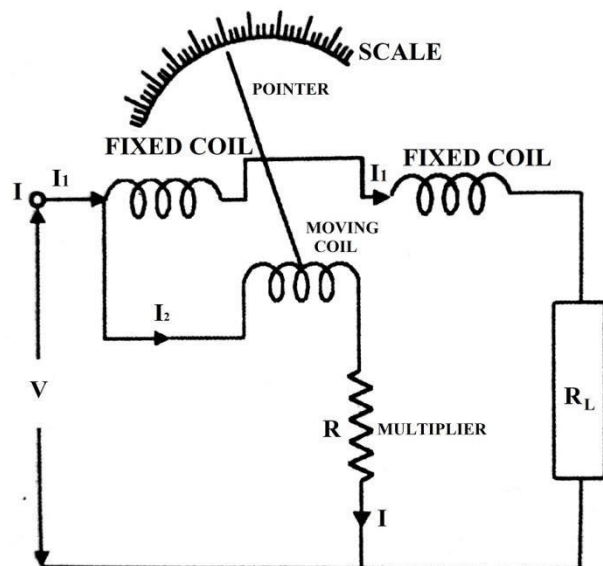

PRINCIPLE OF OPERATION:

When the current flows through the fixed coil, it produced a magnetic field, whose flux density is proportional to the current through the fixed coil. The moving coil is kept in between the fixed coil. When the current passes through the moving coil, a magnetic field is produced by this coil. The magnetic poles are produced in such a way that the torque produced on the moving coil deflects the pointer over the calibrated scale. This instrument works on AC and DC. When AC voltage is applied, alternating current flows through the fixed coil and moving coil. When the current in the fixed coil reverses, the current in the moving coil also reverses. Torque remains in the same direction. Since the current i_1 and i_2 reverse simultaneously. This is because the fixed and moving coils are either connected in series or parallel.

Errors in dynamometer type instruments

- **Frictional Error:** Since the coils are air-cored, therefore the magnetic field produced is of small strength. So they require a large number of ampere-turns to create necessary deflecting torque. This result in the heavy moving system. Therefore small torque-weight ratio. Thus the frictional losses in dynamo type instruments are somewhat larger as compared to other instruments.
- **Temperature errors:** Since the operation of dynamo type instrument required considerable power, self heating in these instrument is appreciable. The error due to self heating may be much as 1% of full scale deflection.
- **Error Due to Stray Magnetic field:** Since the operating magnetic field produced by the fixed coil. In these instruments is somewhat weaker in comparison to that in the instrument of other type. The operation of these instruments is more sensitive to the stray magnetic field.
- **Frequency error:** The change in frequency causes error
 - Due to change in reactance of operating coil.
 - Due to change in magnitude of Eddy current setup in the metal part of the instrument near to operating portion.

Advantages of Dynamometer type instrument

- As the instrument has Square Law response so can be used on both the dc as well as on AC.
- These instruments are free from hysteresis and Eddy current errors. It is because of absence of iron in the operating part of the instrument.
- Ammeter up to 10A and voltmeter up to 600V can be constructed with precision grade accuracy.
- Dynamo type voltmeter are useful for accurate measurement of rms value of voltage irrespective of waveform.
- Because of Precision grade accuracy and same calibration for DC and AC measurement instruments are used as transfer and calibration instruments.

Disadvantage of Dynamometer type instrument

- The scale is not uniform as the instrument uses Square Law response. These instruments have small torque-weight ratio so the friction error is considerable.
- Owing to heavy moving system friction losses in these instruments are somewhat more than those in other instruments.
- As a result of measures taken to reduce the frictional errors, their cost is more in comparison to moving iron and PMMC instruments. They are more sensitive to overload and mechanical impact and are to be handled with care.
- Adequate screening of the movements against the stray magnetic field is essential.
- The sensitivity of the instrument is typically very low due to poor deflecting torque. The sensitivity of dynamo type wattmeter is 10 to 30 per volt in comparison to the sensitivity of 20-kilo-ohm per volt in case of D'Arsonval movement.
- The power consumption of this instrument is comparatively high because of their construction.

Ranges:

Ammeter: 1. With fixed and moving coil in series- 0/0.01A-0/0.05 A

2. With moving coil shunted or parallel connection- upto 0/30A.

Voltmeter: Upto 0-750 volts

EXTENSION OF RANGE OF INSTRUMENT BY THE USE OF SHUNT AND MULTIPLIER AMMETER CONNECTION

Shunts are used for the range extension of ammeters. A shunt is a low-value resistance having minimum temperature co-efficient and is connected in parallel with the ammeter whose range is to be extended. The combination is connected in series with the circuit whose current is to be measured.

The ratio of maximum current (with shunt) to the full-scale deflection current (without shunt) is known as the 'multiplying power' or 'multiplying factor' of the shunt.

Example: A moving coil ammeter reading up to 1 ampere has a resistance of 0.02 ohm. How could this instrument be adopted to read current up to 100 amperes.

Solution: In this case,

Full-scale deflection current of the ammeter, $I_m = 1 \text{ A}$

Line current to be measured, $I = 100 \text{ A}$

Resistance of ammeter, $R_m = 0.02 \text{ ohm}$

Let, the required shunt resistance = S

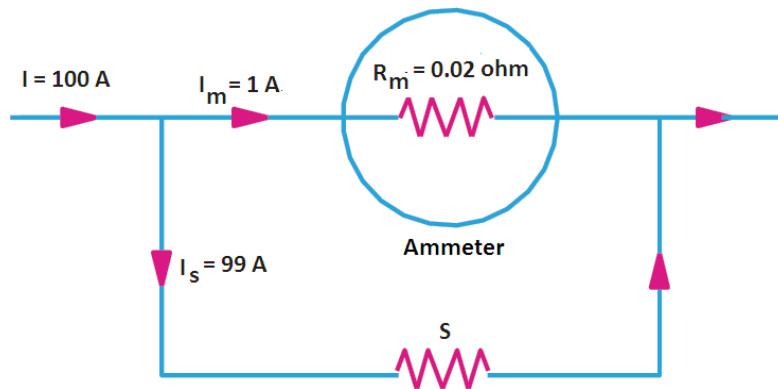

As seen from Figure, the voltage across the instrument coil and the shunt resistance is the same since both are joined in parallel.

$$\therefore I_m R_m = S I_s = S(I - I_m)$$

$$\text{or } S = I_m R_m / (I - I_m)$$

$$= 1 \times 0.02 / (100 - 1) = 0.02 / 99 = 0.000202 \text{ Ans.}$$

VOLTMETER CONNECTION

Multipliers are used for the range extension of voltmeters. The multiplier is a non-inductive high-value resistance connected in series with the instrument whose range is to be extended. The combination is connected across the circuit whose voltage is to be measured.

Example: A moving coil voltmeter reading upto 20 mV has a resistance of 2 ohms. How this instrument can be adopted to read voltage upto 300 volts.

Solution: In this case,

Voltmeter resistance, $R_m = 2\text{ ohm}$

Full-scale voltage of the voltmeter, $v = R_m I_m = 20\text{ mV} = 0.02\text{ V}$

Full-scale deflection current, $I_m = v / R_m = 0.02 / 2 = 0.01\text{ A}$

Voltage to be measured, $V = 300\text{ V}$

Let the series resistance required $= R$

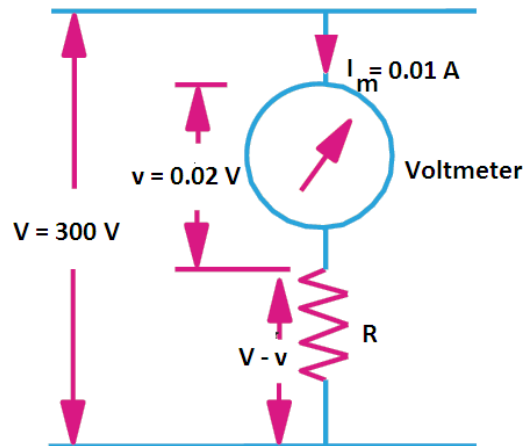

Then as seen from figure, the voltage drop across R is $V - v$

$$R I_m = V - v$$

$$\text{or } R = (V - v)/I_m$$

$$\text{or } R = (300 - 0.02)/0.01 = 299.98/0.01 = 29998 \text{ ohms } \mathbf{Ans.}$$

RECTIFIER TYPE INSTRUMENT

A **rectifier type instrument** measures alternating electrical signal by means of D.C measuring instrument. As the name implies, this instrument first rectifies an A.C signal to D.C then measures. Although it measures the rectified A.C signal (D.C signal), but the scale of the instrument is calibrated for A.C. The sensitivity of D'Arsonval instrument is quite high. But a D'Arsonval instrument can only measure to D.C. So, to utilize the sensitivity of D'Arsonval movement for A.C, we use a **rectifier type instrument**.

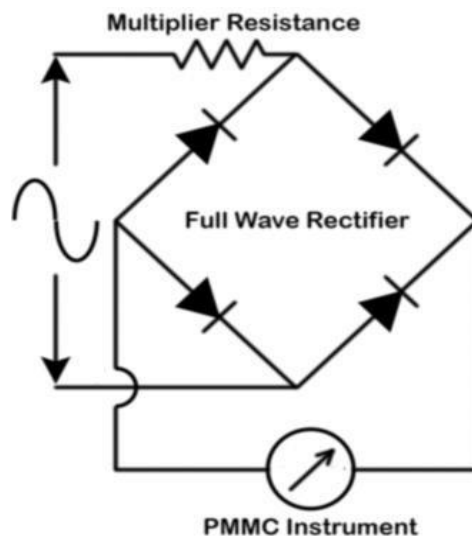

Rectifier Elements for Rectifier Type Instrument

To convert A.C. to D.C, a rectifier instrument must have some rectifier elements.

At the low-frequency range, the instrument uses copper oxide or selenium cells for rectification purpose. Again at higher frequencies, we use germanium or silicon diodes.

The copper oxide rectifier element has a peak inverse voltage (PIV) about 2 volts. On the other hand, the selenium element has PIV of 10 volts. Also, both of these rectifier elements have very low current handling capacity. Therefore, for rectification purpose, these elements have become obsolete in the modern era.

Besides it, a germanium diode has a peak inverse voltage (PIV) of about 300 volts. In addition to that, the current carrying capacity of a germanium diode is about 100 mA. Also, PIV of silicon diode is about 1000 volts with a current rating of 5000 mA. Therefore these germanium and silicon diodes have become most suitable choice as rectifier elements for the purposes.

Advantages of Rectifier Type Instrument

1. This instrument can measure an electrical signal of very low frequency to radio frequency.
2. The instrument is also capable of measuring electrical signals up to several mega Hz.
3. The sensitivity of the instrument is much higher than that of any other type of A.C measuring instruments. Actually, for achieving very high sensitivity in A.C measurements, we use **rectifier type instruments**.

Characteristic of Rectifier Type Instrument

1. A rectifier type instrument is an economical and suitable mean of A.C measurement.
2. It can measure the electrical signal at an audio frequency range.
3. The sensitivity of the instrument is much higher than a commonly used A.C measuring instrument. It has been found that the sensitivity of a general rectifier type instrument is around 50 times higher than of a dynamometer type instrument or a moving iron type instrument.
4. Generally, D' Arsonval movement is uniform; therefore a rectifier type instrument generally has a linear scale.
5. The sensitivity of the instrument is in order of 1000 to 2000 ohms/volt.
6. The power consumption of a rectifier type instrument is high because of the resistance of the rectifier elements.
7. Shunting of the rectifier instrument is not practical because the resistance of rectifier elements changes with the temperature and the current flowing through it.
8. The rectifier type instrument is capable of measuring a very tiny current of microampere range. Again it can also be capable of measuring current in the milliampere range. But we do not construct a rectifier type instrument beyond for the current of 15mA. Because it requires special sized rectifier elements and the size of the instruments becomes impracticality large.

INDUCTION TYPE INSTRUMENT

The operation of Induction type instruments depends on the production of torque due to reaction between two magnetic fluxes having some phase difference or reaction between flux of an AC magnet and the eddy current induced by this flux. This instrument having an aluminum disc (or aluminum drum) in the magnetic field. Hence, the changing flux links with the aluminum disc. As a result, the flux induces an eddy current on the disc. This eddy current interacts with the flux which has induced it. Consequently, there is a mechanical torque acting on the disc. This mechanical torque rotates the disc. These type of instruments are used only for AC measurements.

Torque in Induction Type Instrument

So, the torque depends on two factors. The first one is the strength of the field of the electromagnet. The second one is the value of eddy current on the disc. Of course, the torque is proportional to the strength of the magnetic field. Also, it is proportional to the eddy current. Again, the strength of the magnetic field depends on the current of the electromagnet. On the other hand, the value of eddy current depends on the strength of the magnetic field. So, we can say, the value of eddy current also depends on the current of the electromagnet.

So, the torque acting on the disc is directly proportional to the square of the current of the electromagnet. In an induction type instrument, we directly feed the measuring current into the coil of the electromagnet. Therefore, the deflecting torque is directly proportional to the square of the measuring current.

Let us consider the flux, produced by the electromagnet is

$$\phi = \phi_m \sin \theta$$

The phase angle between that flux and induced eddy current is α . Hence, we can write the expression of the eddy current as

$$i = I_m \sin(\theta - \alpha)$$

Again, the instantaneous torque is directly proportional to the instantaneous eddy current and the flux. Hence, we can write,

$$T_{ins} \propto \phi i$$

So, the mean torque is as follows,

$$\begin{aligned}
 T_m &\propto \frac{1}{\pi} \int_0^\pi \phi i d\theta \\
 \Rightarrow T_m &\propto \frac{1}{\pi} \int_0^\pi \phi_m \sin(\theta) I_m \sin(\theta - \alpha) d\theta \\
 \Rightarrow T_m &\propto \frac{\phi_m I_m}{2\pi} \int_0^\pi [\cos\alpha - \cos(2\theta - \alpha)] d\theta \\
 \Rightarrow T_m &\propto \frac{\phi_m I_m}{2\pi} \left[\theta \cos\alpha - \frac{\sin(2\theta - \alpha)}{2} \right]_0^\pi \\
 \Rightarrow T_m &\propto \frac{\phi_m I_m}{2\pi} (\pi \cos\alpha) \Rightarrow T_m \propto \frac{\phi_m I_m}{2} \cos\alpha \\
 \Rightarrow T_m &\propto \phi_{RMS} I_{RMS} \cos\alpha
 \end{aligned}$$

The above expression tells that the torque is zero if α is 90° . Hence to obtain resulting torque it is necessary to produce an eddy current which is either less than or more than 90° out of phase with flux ϕ . α is the phase angle between the flux and eddy current.

So, there must be some means in induction type instrument to prevent this phase angle from being 90° . We can achieve this by two methods listed below.

1. Split-phase type and
2. Shaded pole type

1. SPLIT-PHASE TYPE INDUCTION TYPE INSTRUMENT:

In this arrangement, there are two AC magnets P1 and P2 connected in series. The winding in P2 is shunted by a resistance R. The current in the P2 winding lags with respect to the total current. This helps to develop the necessary phase angle α between the two fluxes. Eddy current damping is used in this type of instrument.

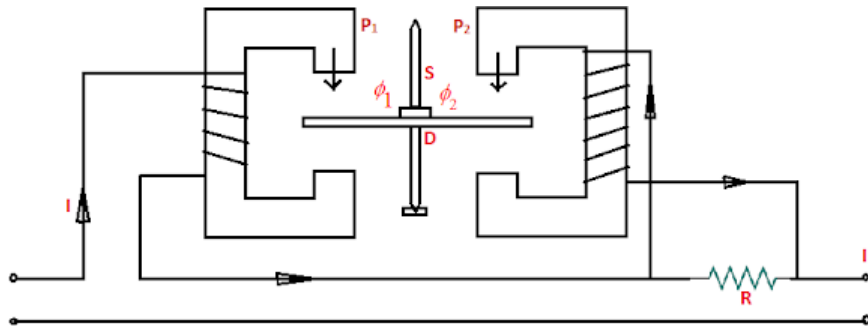

2. SHADDED POLE TYPE INDUCTION TYPE INSTRUMENT:

Shaded pole type induction instrument uses a single winding to produce flux. The flux produced by this winding is split up into two fluxes, having phase difference with respect to each other. The phase difference is usually 40 to 50 degrees and can be varied by varying the size of shading band. This is done by making a narrow slot in the poles of electromagnet. A copper strip is placed around the smaller of the two areas formed by the slot. This copper shading band acts as a short circuited secondary winding.

The exciting coil is placed on the poles and a current proportional to current or voltage being measured is passed through it. An aluminium disc which is mounted on a spindle is inserted in the air gap of the electromagnet. The spindle carries a pointer and has a control spring attached to it. The controlling torque is provided by this spring only.

Damping is provided by a permanent magnet placed at the opposite side of the electromagnet, so that the disc can be used for production of both deflecting and damping torque.

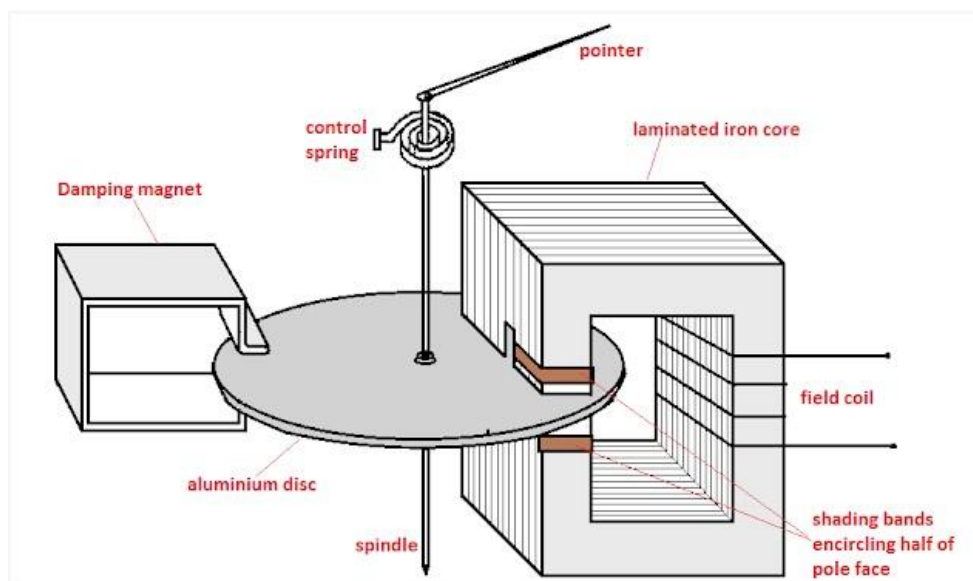

CHAPTER-2

MEASUREMENT OF POWER

DYNAOMETER TYPE WATTMETER

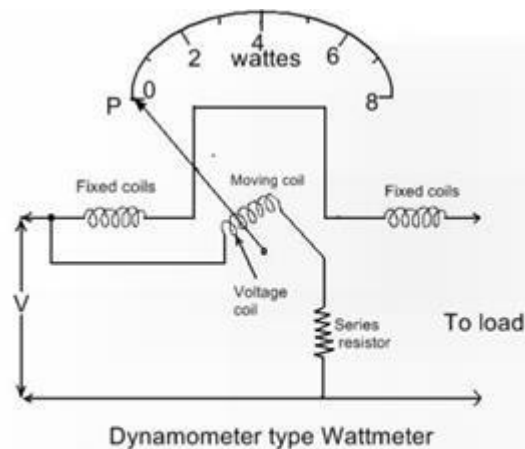

A dynamometer type wattmeter primarily consists of two coils called fixed coil and moving coil. The fixed coil is splitted into two equal parts, which are placed parallel to each other. The two fixed coils are air-cored to avoid hysteresis effects when used on AC.

The fixed coil is connected in series with the load and carries the circuit current. It is, therefore, called the current coil. The moving coil is pivoted between the two parts of the fixed coil and is mounted on a spindle.

A pointer is attached to the spindle, which gives deflection. The moving coil is connected in parallel with the load and carries the current proportional to the voltage. It is, therefore, called the potential coil. Generally, a high resistance is connected in series with the moving coil to limit the current through it. By limiting the current, the moving coil is made lightweight, which in turn increases the sensitivity of the instrument.

The springs provide the controlling torque. They also serve the additional purpose of leading the current into and out of the moving coil. Air friction damping is employed in such instruments.

Dynamometer Type Wattmeter Working

We use the wattmeter for power measurements. Its current coil is connected in series with the load, carries the load current, and the potential coil, connected in parallel with the load, carries the current proportional to the voltage across the load.

The fixed coil produces a field F_m , and moving coil creates a field F_r . The field F_r tries to come in line with the main field F_m , which provides a deflecting torque on the moving coil.

Thus, the pointer attached to the spindle of the moving coil deflects. This deflection is controlled by the controlling torque produced by the springs. Also read Power Measurements in Three Phase Circuits.

Advantages and Disadvantages of Dynamometer Type Wattmeter

Advantages:

- It can be used both on AC and DC circuits.
- It has a uniform scale.
- We can obtain a high degree of accuracy through careful design.

Disadvantages:

- At low power factors, the inductance of the potential coil causes serious errors.
- The reading of the instrument may be affected by stray fields acting on the moving coil. To prevent it, magnetic shielding is provided by enclosing the instrument in an iron case.

Errors in Dynamometer Type Wattmeter

Errors in this type of wattmeter:

1. Error due to potential coil inductance: The inductance of the potential coil is liable to cause an error in the reading of the wattmeter. Because of this error, the wattmeter gives a high reading on lagging power factor and low reading on leading power factor.

The high non-inductive resistance connected in series with the coil swamps the phasing effect of the potential coil inductance.

2. Error due to power loss in the potential coil or current coil: Another possible error in the indicated power may be due to some voltage drop in the current coil or the current taken by the potential coil.

We can overcome this defect by using an additional compensating winding. This winding is connected in series with the potential coil and so placed that it produces a field in the opposite direction to that of the current coils.

3. Error due to eddy currents: The alternating field of fixed or current coil induces eddy currents in the solid metal parts which set up their own magnetic field. This alters the magnitude and phase of the magnetic field, causing deflection.

Thus an error is introduced in the instrument reading. To reduce this error, the solid metal parts are placed far away from the current coil as possible.

4. Error due to the stray magnetic field: The dynamometer type wattmeter has a relatively weak operating field; therefore, stray fields affect the reading of this instrument considerably and cause serious errors.

Hence, this type of instrument must be shielded against stray magnetic fields by using iron cases or providing thin iron shields over the working parts.

Range

- Current circuit 0 – 0.25A to 0 – 100A without employing CTs.
- Potential circuit 0 – 5 V to 0 – 750 V without using PTs.

INDUCTION TYPE WATTMETER

The induction type wattmeter is used to measure a.c power only.

Principle of Induction type wattmeter:

The principle of operation of an induction wattmeter is same as that of induction ammeters and voltmeters i.e. induction principle. However, it differs from induction ammeter or voltmeter in so far that separate two coils are used to produce the rotating flux in place of one coil with phase split arrangement.

Construction of Induction type wattmeter:

The principle parts of an induction wattmeter are as shown in the fig below. It consists of two laminated electromagnets. One electromagnet, called shunt magnet is connected across supply and carries current proportional to the applied voltage. The coil of this magnet is made highly inductive so that the current in it lags behind the supply voltage by 90 degrees. The other electromagnet, called series magnet is connected in series with supply and carries the load current. The coil of this magnet is made highly non inductive so that the angle of lag or lead is determined fully by the load.

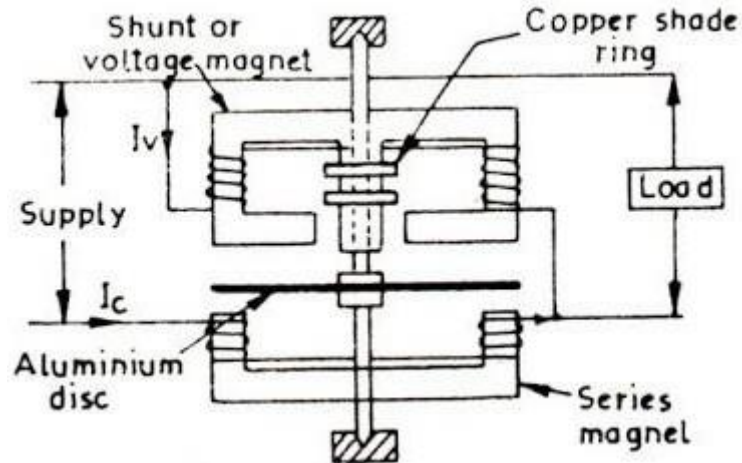

A thin aluminium disc mounted on the spindle is placed in between the two magnets so that it cuts the fluxes of both the magnets. The controlling torque is provided by spiral springs. The damping is electromagnet and is usually provided by a permanent magnet embracing the aluminium disc. Two or more closed copper rings, called shading rings are provide on the central limb of the shunt magnet. By adjusting the position of these rings, the shunt magnet flux can be made to lag behind supply voltage by exactly 90degrees.

Working of Induction type wattmeter:

When the wattmeter is connected in the circuit to measure a.c power, the shunt magnet carries current proportional to the supply voltage and the series magnet carries the load current. The two fluxes produced by the magnets induce eddy currents in the aluminium disc. The interaction between the fluxes and eddy currents produce the deflecting torque on the disc, causing the pointer connected to the moving system to move over the scale.

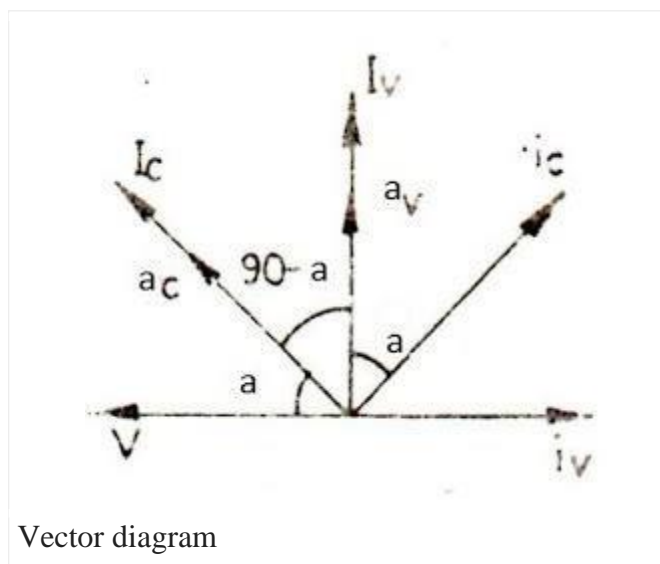

Deflecting torque of Induction type wattmeter:

let V = Applied voltage

I_c = Load current carried by the series magnet

I_v = Current carries by the shunt magnet

$\cos a$ = Lagging power factor of the load

The vector diagram of this wattmeter is shown in the fig below. The current I_v in the shunt magnet lags the applied voltage V by 90 degrees and so does the flux ϕ_v produced by it. The current I_c in the series magnet is the load current and hence lags behind the applied voltage by a' . The flux ϕ_c produced by this current I_c is in phase with it. Therefore the two currents I_c in the current coil and I_v in the voltage coil and also corresponding fluxes ϕ_v and ϕ_c are $(90 - a')$ apart.

The flux ϕ_c induces the eddy currents i_v in the aluminium disc which lags behind the flux by 90 degrees. Similarly, flux ϕ_v induces eddy currents i_c which again lags behind flux ϕ_v by 90 degrees.

Mean deflecting torque, T_d proportional $\phi_c \sin (90 - a)$

T_d proportional $V I \cos a$

T_d proportional a.c power

Since control is by springs, therefore

T_c proportional deflection

For steady deflected position, $T_d = T_c$

Deflection proportional power

Hence, such instruments have uniform scale.

CHAPTER 4- MEASUREMENT OF ENERGY

SINGLE PHASE INDUCTION TYPE ENERGY METERS:

Induction type energy meter consists of the following components:

(a) Driving system (b) Moving system (c) Braking system and (d) Registering system.

- Driving system: The construction of the electro magnet system is shown in Fig. 44.1(a) and it consists of two electromagnets, called “shunt” magnet and “series” magnet, of laminated construction.

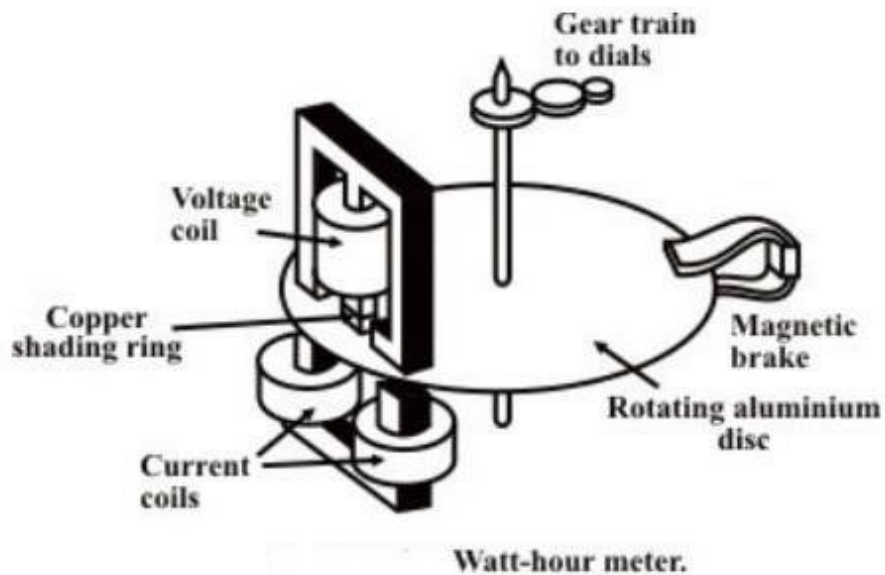

Figure 1

A coil having large number of turns of fine wire is wound on the middle limb of the shunt magnet. This coil is known as “pressure or voltage” coil and is connected across the supply mains. This voltage coil has many turns and is arranged to be as highly inductive as possible. In other words, the voltage coil produces a high ratio of inductance to resistance. This causes the current, and therefore the flux, to lag the supply voltage by nearly 90° . An adjustable copper shading rings are provided on the central limb of the shunt magnet to make the phase angle displacement between magnetic field set up by shunt magnet and supply voltage is approximately 90° . The copper shading bands are also called the power factor compensator or compensating loop. The series electromagnet is energized by a coil, known as “current” coil which is connected in series with the load so that it carry the load current. The flux produced by this magnet is proportional to, and in phase with the load current.

- Moving system: The moving system essentially consists of a light rotating aluminium disk mounted on a vertical spindle or shaft. The

shaft that supports the aluminium disk is connected by a gear arrangement to the clock mechanism on the front of the meter to provide information that consumed energy by the load. The time varying (sinusoidal) fluxes produced by shunt and series magnet induce eddy currents in the aluminium disc. The interaction between these two magnetic fields and eddy currents set up a driving torque in the disc. The number of rotations of the disk is therefore proportional to the energy consumed by the load in a certain time interval and is commonly measured in kilowatt-hours (Kwh).

- Braking system: Damping of the disk is provided by a small permanent magnet, located diametrically opposite to the a.c magnets. The disk passes between the magnet gaps. The movement of rotating disc through the magnetic field crossing the air gap sets up eddy currents in the disc that reacts with the magnetic field and exerts a braking torque. By changing the position of the brake magnet or diverting some of the flux there from, the speed of the rotating disc can be controlled.

Let us consider a sinusoidal flux $\phi(t)$ is acting perpendicularly to the plane of the aluminium disc, the direction of eddy current i_e by Lenz's law is indicated in figure Fig. 2. It is now quite important to investigate whether any torque will develop in aluminium disc by interaction of a sinusoidally varying flux $\phi(t)$ and the eddy currents i_e induced by itself.

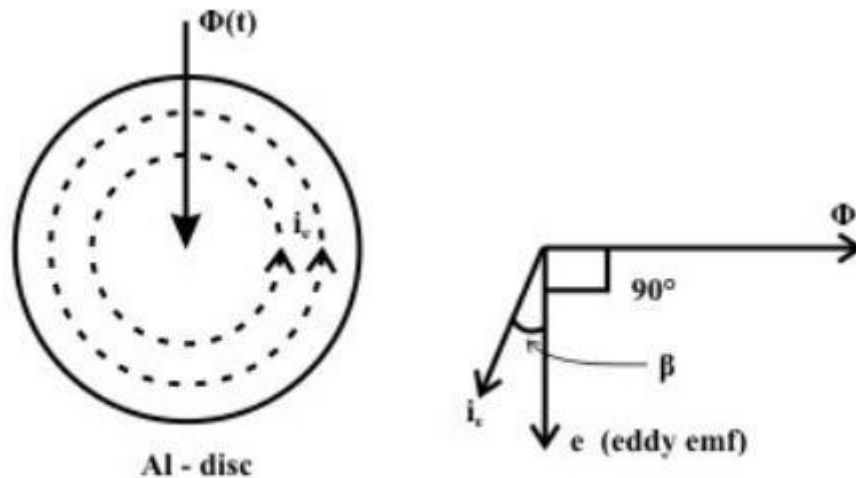

Fig. 2 : Eddy currents in aluminium disc due to time-varying flux.

$$\begin{aligned}
 T_{d(av)} &\propto \phi I_e \cos(\angle \phi, I_e) = \phi I_e \cos(90^\circ + \beta) \\
 &\propto \phi I_e \sin(\beta) = 0
 \end{aligned}
 \tag{1}$$

where ϕ and I_e are expressed in r.m.s and $\beta=0$ (because the reactance of the aluminium disc is nearly equal to zero). Therefore, the interaction of a sinusoidally varying flux $\phi(t)$ and its own eddy current i_e (induced) cannot produce torque any on the disc.

So in all induction instruments we have two fluxes produce by currents flowing in the windings of the instrument. These fluxes are alternating in nature and so they induce emfs in a aluminium disc or a drum provided for the purpose. These emfs in turn circulate eddy currents in the disc.

As in an energy meter instrument, we have two fluxes and two eddy currents and therefore two torques are produced by

- i) first flux(ϕ_1) interacting with the eddy currents (I_{e2}) generated by the second flux(ϕ_2), and
- ii) second flux (ϕ_2) interacting with the eddy currents (I_{e1}) induced by the first flux (ϕ_1).

In the induction type single phase energy meter, the flux produced by shunt magnet (pressure or voltage coil current) Φ_{sh} lags behind the applied voltage V by almost 90° . The flux ϕ_{se} is produced by the load current I and Φ_{se} is in the direction of I .

Let the supply voltage $v(t) = V_{\max} \sin(\omega t)$ and load current $i(t) = I_{\max} \sin(\omega t - \theta)$. So, the fluxes are :

Let the supply voltage $v(t) = V_{\max} \sin(\omega t)$ and load current $i(t) = I_{\max} \sin(\omega t - \theta)$. So, the fluxes are :

(i) Flux generated by current coil

$$\Phi_{se} = k I_{\max} \sin(\omega t - \theta) = \Phi_{\max(se)} \sin(\omega t - \theta)$$

(ii) Flux generated by voltage coil

$$\begin{aligned} \Phi_{sh} &= k' \int v(t) dt \\ &= -k' \frac{V_{\max}}{\omega} \cos(\omega t) = \Phi_{\max(sh)} \sin(\omega t - 90^\circ) \end{aligned}$$

(note: $v(t) = \frac{1}{k'} \frac{d(\Phi_{sh})}{dt}$ and k and k' are constants.)

The eddy e.m.f, induced by flux Φ_{se} is

$$e_{se} \propto -\frac{d}{dt}(\Phi_{se}) = -k I_{\max} \omega \cos(\omega t)$$

Eddy current generated in disc by the current coil

$$i_{se} \propto -\frac{k}{Z} I_{\max} \omega \cos(\omega t - \theta - \alpha) = \frac{k}{Z} I_{\max} \omega \sin(\omega t - (\theta + \alpha + 90^\circ)),$$

where Z is the eddy current path impedance and α is the phase angle. In general, the angle $\alpha = \tan^{-1} \frac{X}{R}$ is negligible because $X = 0$.

Also, note that

$$e_{sh} \propto -\frac{d}{dt}(\phi_{sh}) = -k' \frac{V_{max}}{\omega} \omega \sin(\omega t)$$

Eddy current generated in disc by the voltage coil

$$i_{sh} \propto -k' \frac{V_{max}}{Z} \sin(\omega t - \alpha) = k' \frac{V_{max}}{Z} \sin(\omega t + (180^\circ - \alpha))$$

The instantaneous torque on the disc is then proportional to

$$(\Phi_{sh} i_{se} - \Phi_{se} i_{sh}) = \frac{k k'}{Z} V_{max} I_{max} (\cos(\omega t) \cos(\omega t - \theta - \alpha) - \sin(\omega t - \theta) \sin(\omega t - \alpha))$$

where Φ_{sh} is the flux generated by the voltage coil, Φ_{se} is flux generated by the current coil, i_{sh} is the eddy current produced in the disc by the voltage coil, and i_{se} is the eddy current produced in the disc by the current coil. The relative phases of these quantities are shown in fig.4

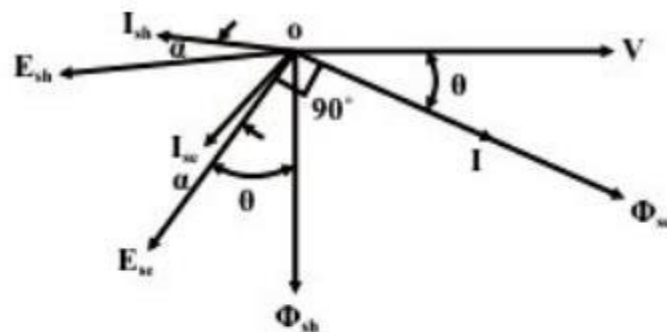

Fig. 4 : Phasor diagram of fluxes and eddy currents in watt-hour meter.

The flux generated by the current coil is in phase with the current and flux generated by the voltage coil is adjusted to be exactly in quadrature with the applied voltage by means of the copper shading ring on the voltage or shunt magnet. Theory of shaded pole is discussed in Appendix. The average torque acting upon the disc

$$T_{d(av)} \propto \frac{k k'}{Z} V_{\max} I_{\max} \frac{1}{2} (\cos(\theta + \alpha) + \cos(\theta - \alpha))$$

$$\propto \frac{k k'}{Z} V_{\max} I_{\max} \cos \alpha \cos \theta = \left(\frac{2 k k'}{Z} \cos \alpha \right) VI \cos \theta$$

$\propto VI \cos \theta = \text{power in the circuit}$

One can write average torque expression directly from the phasor diagram shown in fig.4

$$T_{d(av)} \propto \left[\Phi_{sh(rms)} I_{se} \cos(\angle \Phi_{sh(rms)}, I_{se}) - \Phi_{se(rms)} I_{sh} \cos(\angle \Phi_{se(rms)}, I_{sh}) \right]$$

$$\propto \left[\Phi_{sh(rms)} I_{se} \cos(\theta + \alpha) - \Phi_{se(rms)} I_{sh} \cos(180 + \alpha - \theta) \right]$$

$$\propto \left[k' V k \frac{I}{Z} \cos(\theta + \alpha) + k I k' \frac{V}{Z} \cos(\theta - \alpha) \right]$$

$$\propto \left(\frac{2 k k'}{Z} \cos \alpha \right) VI \cos \theta$$

$\propto VI \cos \theta = \text{power in the circuit}$

where Φ_{sh} , Φ_{se} , I_{sh} , I_{se} , V , and I are all expressed as r.m.s.

ERROS IN ENERGYMETER:

Assuming the supply voltage and frequency constant, the induction type energy may have the following errors:

- i Speed error: Due to the incorrect position of the brake magnet, the braking torque is not correctly developed. This can be tested when meter runs at its full load current alternatively on loads of unity power factor and a low lagging power factor. The speed can be adjusted to the correct value by varying the position of the braking magnet towards the centre of the disc or away from the centre and the shielding loop. If the meter runs fast on inductive load and correctly on non-inductive load, the shielding loop must be moved towards the disc. On the other hand, if the meter runs slow on non-inductive load, the brake magnet must be moved towards the center of the disc.

- ii Meter phase error: An error due to incorrect adjustment of the position of shading band results an incorrect phase displacement between the magnetic flux and the supply voltage (not in quadrature). This is tested with 0.5 p.f. load at the rated load condition. By adjusting the position of the copper shading band in the central limb of the shunt magnet this error can be eliminated.
- iii Friction error: An additional amount of driving torque is required to compensate this error. The two shading bands on the limbs are adjusted to create this extra torque. This adjustment is done at low load (at about 1/4th of full load at unity p.f.).
- iv Creep: In some meters a slow but continuous rotation is seen when pressure coil is excited but with no load current flowing. This slow revolution records some energy. This is called the creep error. This slow motion may be due to (a) incorrect friction compensation, (b) to stray magnetic field (c) for over voltage across the voltage coil. This can be eliminated by drilling two holes or slots in the disc on opposite side of the spindle. When one of the holes comes under the poles of shunt magnet, the rotation being thus limited to a maximum of 180°. In some cases, a small piece of iron tongue or vane is fitted to the edge of the disc. When the position of the vane is adjacent to the brake magnet, the attractive force between the iron tongue or vane and brake magnet is just sufficient to stop slow motion of the disc with full shunt excitation and under no load condition.
 - (v) Temperature effect: Energy meters are almost inherently free from errors due to temperature variations. Temperature affects both driving and braking torques equally (with the increase in temperature the resistance of the induced-current path in the disc is also increases) and so produces negligible error. A flux level in the brake magnet decreases with increase in temperature and introduces a small error in the meter readings. This error is frequently taken as negligible, but in modern energy meters compensation is adopted in the form of flux divider on the break magnet.

Energy meter constant K is defined as

$$K = \frac{\text{No. of revolutions}}{\text{kwh}}$$

In commercial meters the speed of the disc is of the order of 1800 revolutions per hour at full load

CHAPTER-5

MEASUREMENT OF SPEED, FREQUENCY AND POWER FACTOR

DIGITAL TACHOMETER

The technique employed in measuring the speed of a rotating shaft is similar to the technique used in a conventional frequency counter, except that the selection of the gate period is in accordance with the rpm calibration. Let us assume that the rpm of a rotating shaft is R . Let P be the number of pulses produced by the pickup for one revolution of the shaft. Therefore, in one minute the number of pulses from the pickup is $R \times P$. Then, the frequency of the signal from the pickup is $(R \times P)/60$. Now, if the gate period is G s the pulses counted are $(R \times P \times G)/60$. In order to get the direct reading in rpm, the number of pulses to be counted by the counter is R . So we select the gate period as $60/P$, and the counter counts $(R \times P \times 60)/60P = R$ pulses and we can read the rpm of the rotating shaft directly. So, the relation between the gate period and the number of pulses produced by the pickup is $G = 60/P$. If we fix the gate period as one second ($G = 1$ s), then the revolution pickup must be capable of producing 60 pulses per revolution. Figure shows a schematic diagram of a digital tachometer.

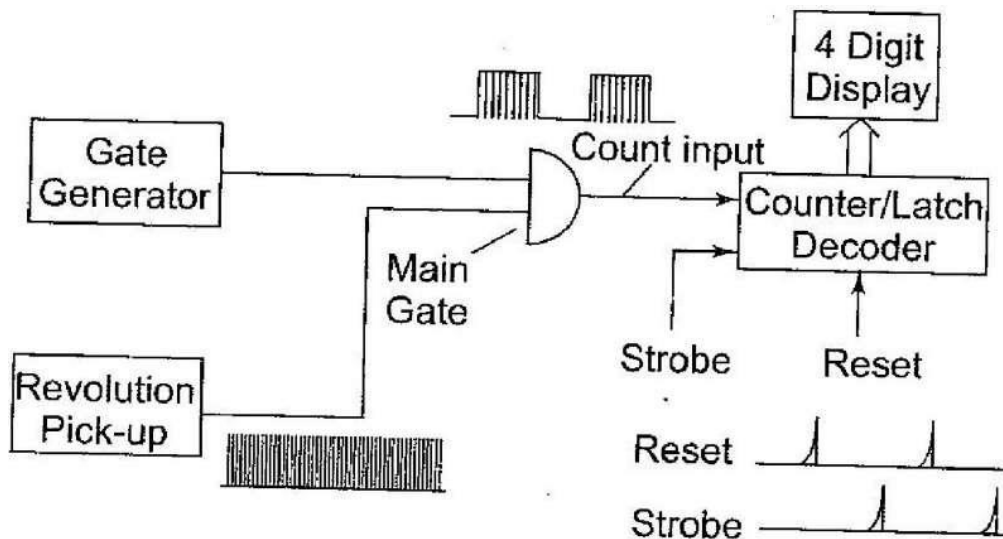

Basic Block Diagram of a Digital Tachometer

MECHANICAL RESONANCE TYPE FREQUENCYMETER:

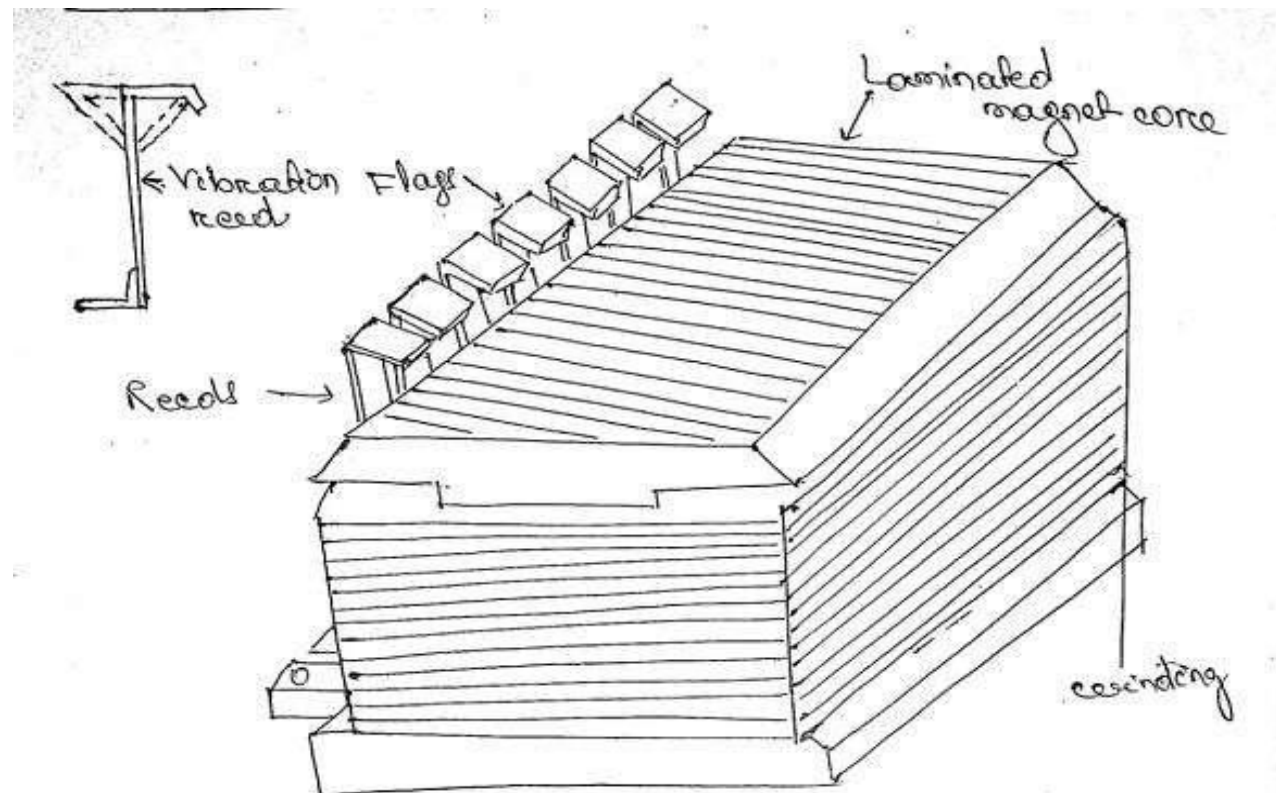

CONSTRUCTION:-

- The meter consists of number of thin steel strips, known as reeds. These reeds are arranged alongside and close to a electromagnet.
- The electromagnet is a laminated iron core. and its coil is connected in series with a resistance across the supply circuit whose freq. is to be measured.
- Bottom portion of reeds are fixed and upper portion is kept free to vibrate. At the free end reeds are bent to form a flag. The reeds are painted white to distinguish them against black background.

- The reeds have either different dimensions or carry different weights or flags at their tops.
- The reeds are so designed and arranged that the natural freq. of one reed is differ from another by one or half cycle. so of the freq. meter has a range of 47 - 53 Hz then natural freq. of first reed will be 47 Hz and 2nd reed be 47.5 Hz and 3rd be 48 Hz and so on.

Operation :-

When the freq. meter is connected across the supply whose freq. is to be measured, the coil of electromagnet carries a current i . Due to the alternating field, a force of attraction is experienced between the reed and the electromagnet, which is proportional to i^2 and i . This force varies at twice the supply frequency. Thus the force is exerted on the reed to vibrate every half cycle. As a result all the reeds will tend to vibrate but the reeds whose natural freq. is equal to twice the supply freq. will vibrate with max^m amplitude. The vibration of other reeds are so slight as to be unobserved. The freq. is determined, by noting the scale reading opposite the reed that vibrates with max^m amplitude. If two adjacent reeds vibrate with equal amplitude then the supply freq. will be half way between the frequencies of two adjacent reeds.

The usual range of freq. meters of this type is about 6 Hz (say from 47 Hz to 53 Hz)

- 1) Show the condⁿ when the meter is not connected to the supply
- 2) Show the condⁿ when 50 Hz reed is vibrating with its max^m amp. amplitude.
- 3) Show the condⁿ when the freq. is exactly midway between 49.5 Hz and 50 Hz.

(Indication from vibrating reeds)

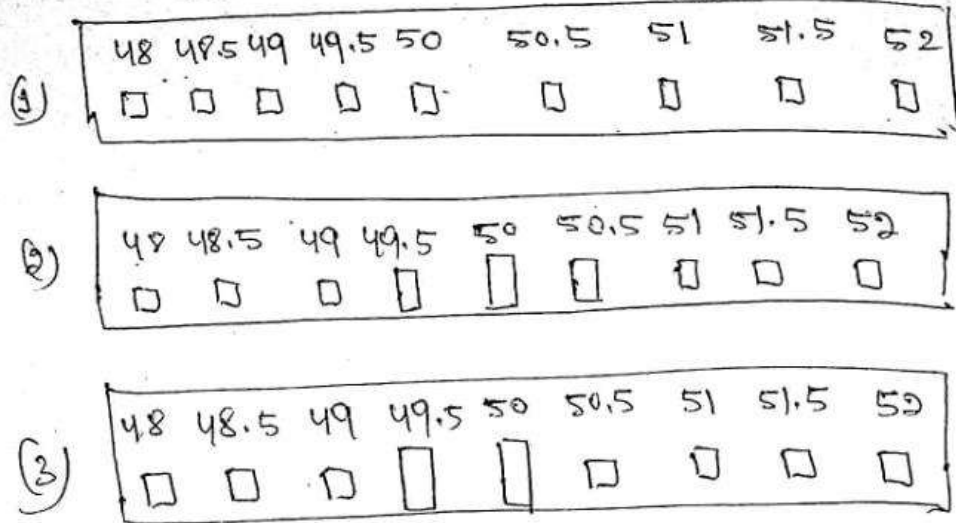

The range of the instrument may be doubled by polarizing its reeds. The polarizing may be done by using a dc winding in addition to the ac winding or by using a permanent magnet.

In the presence of alternating flux, the reeds are attracted two times in a cycle and the reed whose freq. is twice the supply freq. will respond. If the electromagnet is polarized by dc coil in addition to ac coil, the fields (ac and dc) will cancel each other in one half cycle, & reinforce each other in other half cycle, so the reed will be attracted only once in a cycle. Thus a reed whose natural freq. is 100 Hz will respond to 50 Hz when the electromagnet is unpolarized and to 100 Hz when the electromagnet is polarized.

Advantages

The freq. to be measured is independent of waveform of supply voltage.

Disadvantage:

1. Amplitude of vibration depends upon the voltage and if voltage is too low to give appreciable amplitude of vibration, readings will be unreliable.
2. These are not for precision measurement of frequency since adjacent reads have only difference of 0.5 Hz of natural frequency.

Electrical Resonance Type Frequency meter

① Ferrodynamic type Freq. meter

Construction: It consists of fixed coil which is connected across the supply whose freq. is to be measured. This coil is called magnetizing coil. The magnetizing coil is mounted at one end of a laminated iron core of varying cross section (max^m near the end where magnetizing coil is mounted and minimum at other end). A moving coil and with a pointer is pivoted over this iron core so that it can move freely over the iron core. The moving coil is connected across a capacitor C.

Working: The opⁿ of the instrument can be understood from the three phasor diagrams,

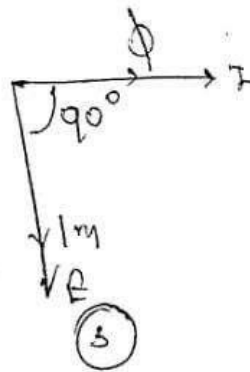
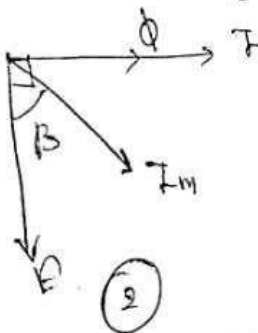
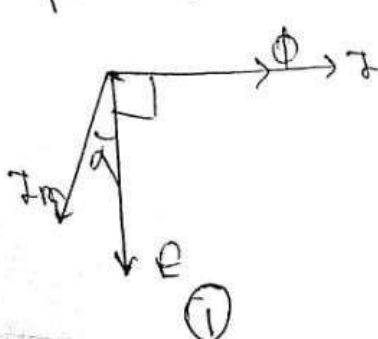

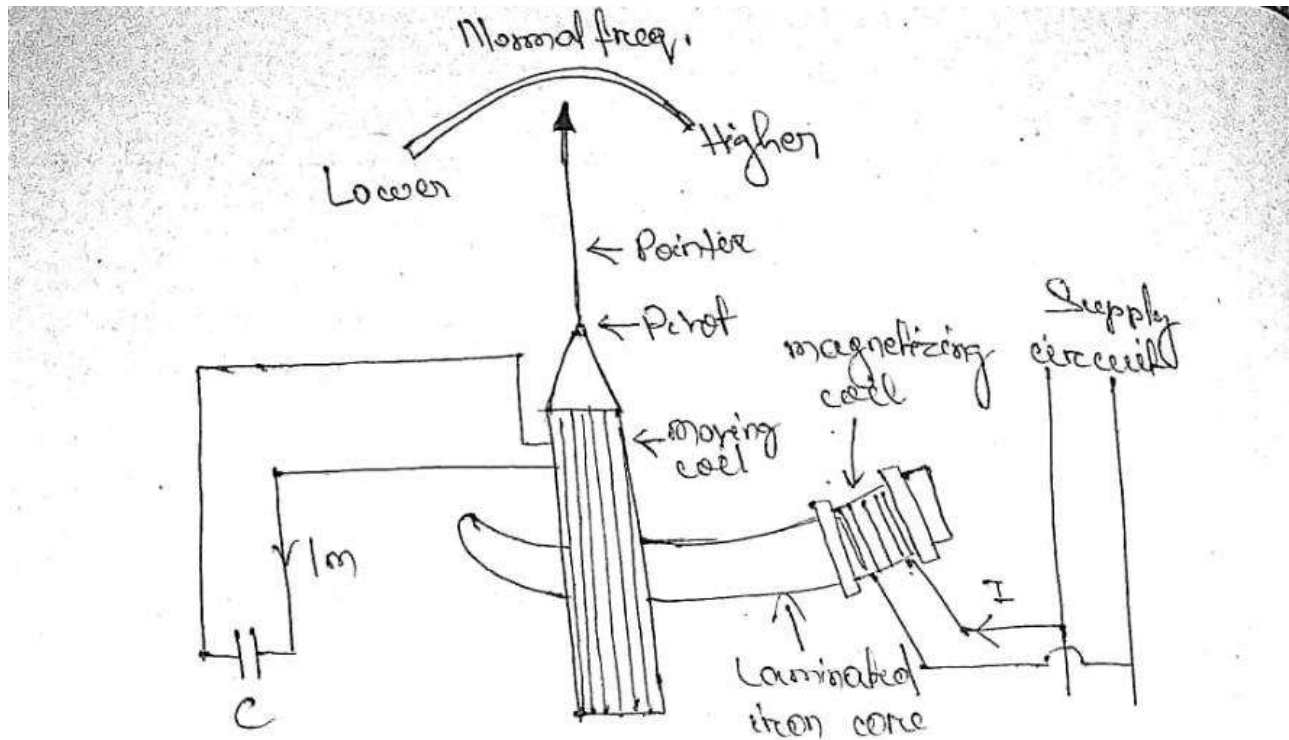

When the magnetizing coil is connected across the supply circuit, current I flows through it and a flux ϕ (in phase with its current I) is produced in the iron core. This flux induces an e.m.f. E in the moving coil which lags behind the flux ϕ by 90° . This e.m.f. E circulates a current I_m in the moving coil. The phase of this current I_m depends on the inductance of the moving coil and the capacitance C .

Factor

(1) when $X_L > X_C$, I_m lags E by α .

$$\therefore T_d \propto I_m \cos(90 + \alpha)$$

(2) when $X_L < X_C$, I_m leads E by β

$$\therefore T_d \propto I_m \cos(90 - \alpha)$$

(3) when $X_L = X_C$, I_m is in phase with E (resonance condⁿ)

$$\therefore T_d \propto I_m \cos 90 = 0$$

For a fixed freq. the capacitive reactance is constant but the X_L of moving coil is not constant. This is bec. X_L depends on the posⁿ occupied by MC on the iron core. X_L becomes max^m when MC is closer to magnetizing coil and minimum when it is at the other end.

Hence the moving coil is pulled towards the magnetizing coil until $X_L = X_C$ or $\omega L = \frac{1}{\omega C}$ and the torque is zero i.e. the circuit of moving coil is in resonance.

The value of C is so chosen that the moving coil take up a mean posⁿ at its normal value. If frequency increases $\frac{1}{\omega C}$ or X_C decreases and X_L i.e. ωL increases. Thus the circuit becomes largely inductive which produce deflecting torque which tries to pull the moving coil to an equilibrium posⁿ i.e. a posⁿ where $X_L = X_C$. This can be obtained by moving the moving coil away from magnetizing coil. The coil moves farther 'on' to the core if freq. decreases.

Advantages Great sensitivity ^{can be} achieved with ~~its use~~ if the inductance of moving coil changes slowly with the variation of its posⁿ on the core.

CHAPTER -6

MEASUREMENT OF RESISTANCE, INDUCTANCE, CAPACITANCE

Explain the working of Wheatstone Bridge(Measurement of Resistance)

For measuring accurately any electrical resistance Wheatstone bridge is widely used. There are two known resistors, one variable resistor and one unknown resistor connected in bridge form as shown below. By adjusting the variable resistor the electric current through the Galvanometer is made zero. When the electric current through the galvanometer becomes zero, the ratio of two known resistors is exactly equal to the ratio of adjusted value of variable resistance and the value of unknown resistance. In this way the value of unknown electrical resistance can easily be measured by using a Wheatstone Bridge.

Wheatstone Bridge Theory

The general arrangement of **Wheatstone bridge circuit** is shown in the figure below. It is a four arms bridge circuit where arm AB, BC, CD and AD are consisting of electrical resistances P, Q, S and R respectively. Among these resistances P and Q are known fixed electrical resistances and these two arms are referred as ratio arms. An accurate and sensitive Galvanometer is connected between the terminals B and D through a switch S₂. The voltage source of this Wheatstone bridge is connected to the terminals A and C via a switch S₁ as shown. A variable resistor S is connected between point C and D. The potential at point D can be varied by adjusting the value of variable resistor. Suppose electric current I₁ and electric current I₂ are flowing through the paths ABC and ADC respectively. If we vary the electrical resistance value of arm CD the value of electric current I₂ will also be varied as the voltage across A and C is fixed. If we continue to adjust the variable resistance one situation may come when voltage drop across the resistor S that is I₂.S becomes exactly equal to voltage drop across resistor Q that is I₁.Q. Thus the potential at point B becomes equal to the potential at point D hence potential difference between these two points is zero hence electric current through galvanometer is nil. Then the deflection in the galvanometer is nil when the switch S₂ is closed.

Now, from Wheatstone bridge circuit

$$\text{current } I_1 = \frac{V}{P+Q}$$

and

$$\text{current } I_2 = \frac{V}{R+S}$$

Now potential of point B in respect of point C is nothing but the voltage drop across the resistor Q and this is

$$I_1 \cdot Q = \frac{V \cdot Q}{P+Q} \text{-----(i)}$$

Again potential of point D in respect of point C is nothing but the voltage drop across the resistor S and this is

$$I_2 \cdot S = \frac{V \cdot S}{R+S} \text{-----(ii)}$$

Equating, equations (i) and (ii) we get,

$$\begin{aligned} \frac{V \cdot Q}{P+Q} &= \frac{V \cdot S}{R+S} \Rightarrow \frac{Q}{P+Q} = \frac{S}{R+S} \\ \rightarrow \frac{P+Q}{Q} &= \frac{R+S}{S} \rightarrow \frac{P}{Q} + 1 = \frac{R}{S} + 1 \rightarrow \frac{P}{Q} = \frac{R}{S} \\ \rightarrow R &= S \times \frac{P}{Q} \end{aligned}$$

Here in the above equation, the value of S and P/Q are known, so value of R can easily be determined. The electrical resistances P and Q of the Wheatstone bridge are made of definite ratio such as 1:1; 10:1 or 100:1 known as ratio arms and S the rheostat arm is made continuously variable from 1 to 1,000 Ω or from 1 to 10,000 Ω .

MAXWELLS BRIDGE:

This bridge is used to find out the self inductor and the quality factor of the circuit. As it is based on the bridge method (i.e. works on the principle of null deflection method), it gives very accurate results. Maxwell bridge is an AC bridge so before going in further detail let us know more about the AC bridge. Let us now discuss Maxwell's inductor bridge. The figure shows the circuit diagram of Maxwell's inductor bridge.

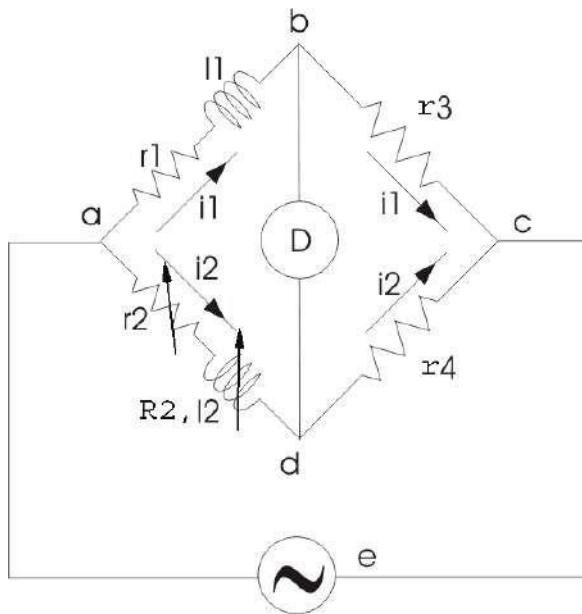

Maxwells Bridge

In this bridge the arms bc and cd are purely resistive while the phase balance depends on the arms ab and ad.

Here L_1 =Unknown inductor of r_1 .

L_2 =Variable inductor of resistance R_2 .

r_2 =variable electrical resistance

As we have discussed in ac bridge according to balance condition, we have at balance point

We can vary R_3 and R_4 from 10 ohms to 10,000 ohms with the help of resistance box.

MAXWELL'S INDUCTANCE CAPACITANCE BRIDGE

In this Maxwell Bridge, the unknown inductor is measured by the standard variable capacitor.

Circuit of this bridge is given below.

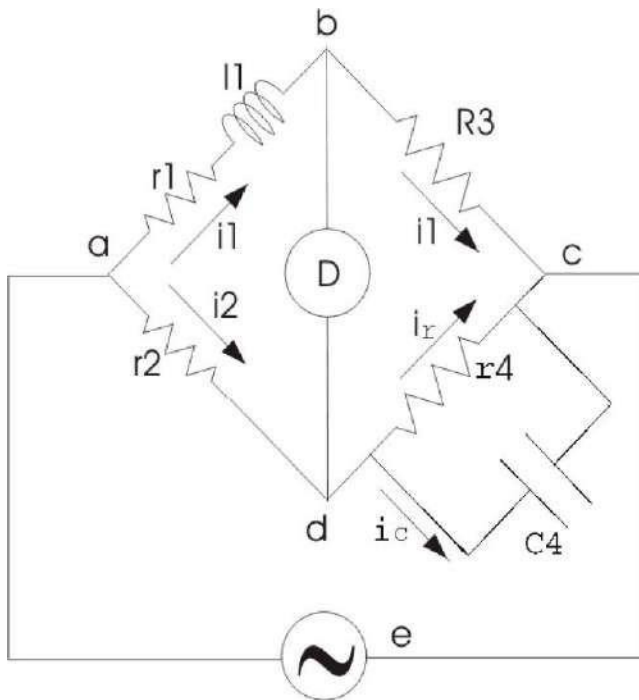

Maxwell's Inductance Capacitance Bridge

Advantages of Maxwell's Bridge

- (1) The frequency does not appear in the final expression of both equations, hence it is independent of frequency.
- (2) Maxwell's inductor capacitance bridge is very useful for the wide range of measurement of inductor at audio frequencies.

Disadvantages of Maxwell's Bridge

- (1) The variable standard capacitor is very expensive.
- (2) The bridge is limited to measurement of low quality coils ($1 < Q < 10$) and it is also unsuitable for low value of Q (i.e. $Q < 1$) from this we conclude that a Maxwell bridge is used suitable only for medium Q coils.

SCHERING BRIDGE THEORY

This bridge is used to measure the capacitance of the capacitor, dissipation factor and measurement of relative permittivity. Let us consider the circuit of Schering bridge as shown below

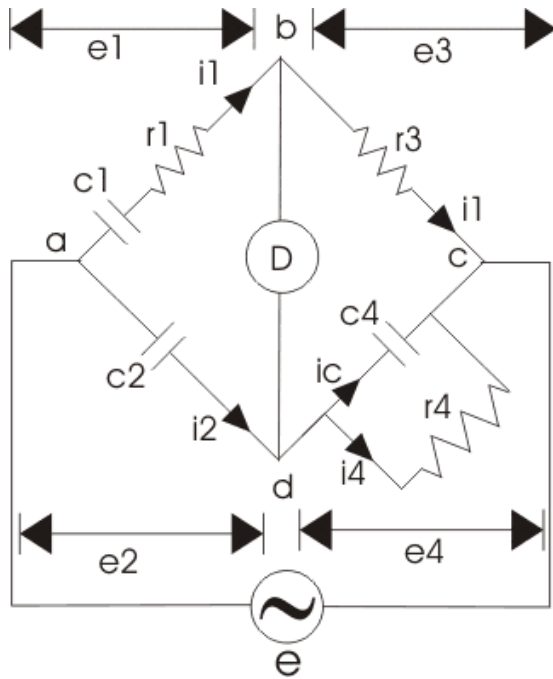

Schering Bridge

Here, c_1 is the unknown capacitance whose value is to be determined with series electrical resistance r_1 .

c_2 is a standard capacitor.

c_4 is a variable capacitor.

r_3 is a pure resistor (i.e. non inductive in nature).

And r_4 is a variable non inductive resistor connected in parallel with variable capacitor c_4 .

Now the supply is given to the bridge between the points a and c. The detector is connected between b and d. From the theory of ac bridges we have at balance condition

$$Z_1 Z_4 = Z_2 Z_3$$

Substituting the values of Z_1 , Z_2 , Z_3 and Z_4 in the above equation, we get

$$\left(r_1 + \frac{1}{j\omega c_1}\right) \left(\frac{r_4}{1 + j\omega c_4 r_4}\right) = \frac{r_3}{j\omega c_2}$$

$$\left(r_1 + \frac{1}{j\omega c_1}\right) r_4 = \frac{r_3}{j\omega c_2} (1 + j\omega c_4 r_4)$$

$$r_1 r_4 - \frac{j r_4}{\omega c_1} = -\frac{j r_3}{\omega c_2} + \frac{r_3 r_4 c_4}{c_2}$$

Equating the real and imaginary parts and separating we get,

$$r_1 = \frac{r_3 c_4}{c_2}$$

$$c_1 = c_2 \frac{r_4}{r_3}$$

Application:

This bridge is used to measure the capacitance of the capacitor, dissipation factor and measurement of relative permittivity.

TRANSDUCERS AND SENSORS

METHOD OF SELECTING TRANSDUCERS

While selecting the proper transducer for any applications, or ordering the transducers the following specifications should be thoroughly considered.

- 1) Ranges available
- 2) Squaring System
- 3) Sensitivity
- 4) Maximum working temperature
- 5) Method of cooling employed
- 6) Mounting details
- 7) Maximum depth
- 8) Linearity and hysteresis
- 9) Output for zero input
- 10) Temperature co-efficient of zero drift
- 11) Natural Frequency.

ADVANTAGES OF ELECTRICAL TRANSDUCERS

1. Very small power is required for controlling the electrical or electronic system
2. The electrical output can be amplified to any desired level
3. Mass inertia effects are reduced to minimum possible.
4. The size and shape of the transducers can be suitably designed to achieve the optimum weight and volume

5. The output can be indicated and recorded remotely at a distance from the sensing medium .
6. The outputs can be modified to meet the requirements of the indicating or controlling equipment.

RESISTIVE TRANSDUCERS

The resistance of a conductor is expressed by a simple equation that involves a few physical quantities . The relationship is given by

$$R = \rho L / A$$

Where , R= resistance, Ω

ρ = Resistivity of conductor materials, $\Omega\text{-m}$

L= Length of conductor, m

A = Cross sectional area of the conductor, m^2

Any method of varying one of the quantities involved in the above relationship can be the designed basis of an electrical resistance transducer. There are a number of ways in which resistance can be changed by a physical phenomenon. The translational and rotational potentiometer which work on the basis of change in the value of resistance with change in length of the conductor can be used for measurement of translational or rotary displacements.

The resistivity of materials changes with the change of temperature thus causing a change of resistance. This property may be used for measurement of temperature. In a resistance transducer an indication of measured physical quantity is given by a change in the resistance. It may be classified as follows

1. Mechanically varied resistance - POTENTIOMETER
2. Thermal resistance change – RESISTANCE THERMOMETER
3. Resistivity change - RESISTANCE STRAIN GAUGE

STRAIN GAUGE

INTRODUCTION

When a metal conductor is stretched or compressed, its resistance changes on account of the fact that both length and diameter of conductor change. The value of resistivity of conductor also changes. When it is strained its property is called piezo-resistance. Therefore, resistance strain gauges are also known as piezo-resistive gauges. The strain gauge is a measurement transducer for measuring strain and associated stress in experimental stress analysis.

TYPES

Four types of Strain gauges are :

1. Wire-wound strain gauge
2. Foil-type strain gauge
3. Semiconductor strain gauge
4. Capacitive strain gauge.

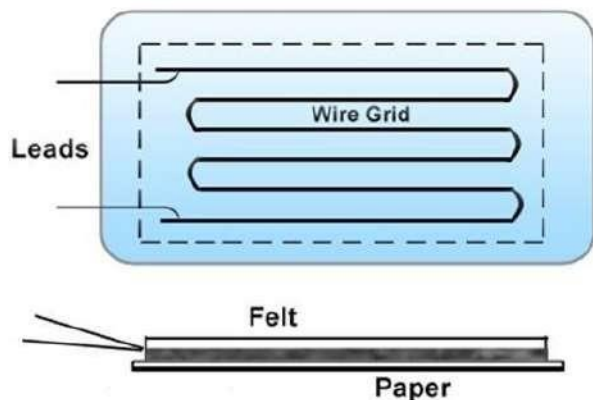

WORKING PRINCIPLE

Strain gauges work on the principle that the resistance of a conductor or a semiconductor changes when strained. This property can be used for measurement of displacement, force and pressure. When a strain gauge is subjected to tension (positive strain) its length increases while

it's crosssectional area decreases. Since the resistance of a conductor is proportional to it's length and inverselyproportional to it's area of cross section, The resistance of the gauge increases with positive strain .Strain gauges are most commonly used in wheat –stone bridge circuits to measure the change ofresistance of grid of wire for calibration proposes; the 'GAUGE FACTOR' is defined as the ratio ofper unit change in resistance to per unit change in length.

i.e , Gauge factor (Gf) = $\Delta R/R \div \Delta L/L$

Where, ΔR = corresponding change in resistance, R

ΔL = Change in length per unit length, L

$R = \rho L/A$

Where, R= resistance, Ω

ρ = Resistivity of conductor materials, $\Omega\text{-m}$

L= Length of conductor, m

A = Cross sectional area of the conductor, m^2

L.V.D.T

LVDT is a passive inductive transducer and is commonly employed to measure force(or weight,pressure and acceleration etc. Which depend on force)in terms of the amount and direction ofdisplacement of an object.

WORKING PRINCIPLE

When the core is in the centre (called reference position) the induced voltages E_1 and E_2 are equal andopposite. Hence they cancel out and the output voltages V_0 is zero.When the external applied force moves the core towards the coil S_2 , E_2 is increased but E_1 isdecreased in magnitude though they are still antiphase with each other. The net voltage available is(E_2-E_1) and is in phase with E_2 .

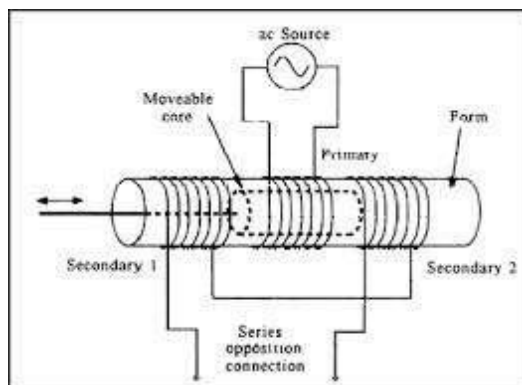

Similarly , When movable core moves towards coil S_1 , $E_1 > E_2$ and $V_0 = E_1 - E_2$ and is in phase with E_1 .

ADVANTAGES

1. It gives a high output and therefore many a times there is no need for intermediate amplification devices.
2. The transducer possess a high sensitivity as high as 40V/mm

3. It shows a low hysteresis and hence repeatability is excellent under all conditions.
4. Most of the LVDTs consume a power of less than 1W.
5. Less friction and less noise

DISADVANTAGES

1. These transducers are sensitive to stray magnetic fields but shielding is possible .This is done byproviding magnetic shields with longitudinal slots.
2. Relatively large displacements are required for appreciable differential output.
3. Several times, the transducer performance is affected by vibrations.

APPLICATIONS

1. Measurement of material thickness in hot strip or slab steel mills
2. In accelerometers.
3. Jet engine controls in close proximity to exhaust gases.

CAPACITIVE TRANSDUCER (PRESSURE)

A linear change in capacitance with changes in the physical position of the moving element may be used to provide an electrical indication of the element's position.

The capacitance is given by $C = KA/d$

where K = the dielectric constant
 A = the total area of the capacitor surfaces
 d = distance between two capacitive surfaces
 C = the resultant capacitance.

From this equation, it is seen that capacitance increases (i) if the effective area of the plate is increased, and (ii) if the material has a high dielectric constant.

The capacitance is reduced if the spacing between the plates is increased.

Transducers which make use of these three methods of varying capacitance have been developed.

With proper calibration, each type yields a high degree of accuracy. Stray magnetic and capacitive effects may cause errors in the measurement produced, which can be avoided by proper shielding. Some capacitive dielectrics are temperature sensitive, so temperature variations should be minimised for accurate measurements.

A variable plate area transducer is made up of a fixed plate called Stator and a movable plate called the Rotor.

The rotor is mechanically coupled to the member under test. As the member moves, the rotor changes its position relative to the stator, thereby changing the effective area between the plates. A transducer of this type is shown in Fig. 13.28.

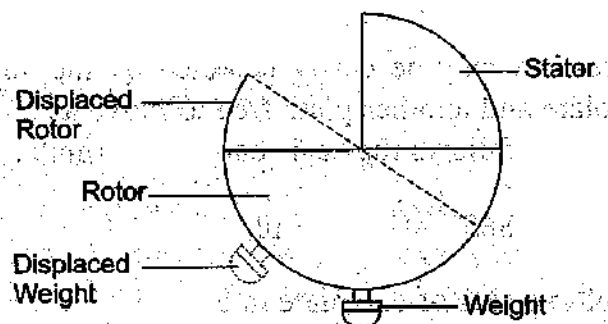

Fig. 13.28 Capacitive Transducer

Such a device is used to detect the amount of roll in an aircraft. As the aircraft rolls to the left, the plates moves to the relative position shown by dashed lines in Fig. 13.28 and the capacitance decreases by an amount proportional to the degree of roll. Similarly to the right. In this case the stator, securely attached to the aircraft, is the moving element. The weight on the rotor keeps its position fixed with reference to the surface of the earth, but the relative position of the plates changes and this is the factor that determines the capacitance of the unit.

Figure 13.29 shows a transducer that makes use of the variation in capacitance resulting from a change in spacing between the plates. This particular transducer is designed to measure pressure (in vacuum).

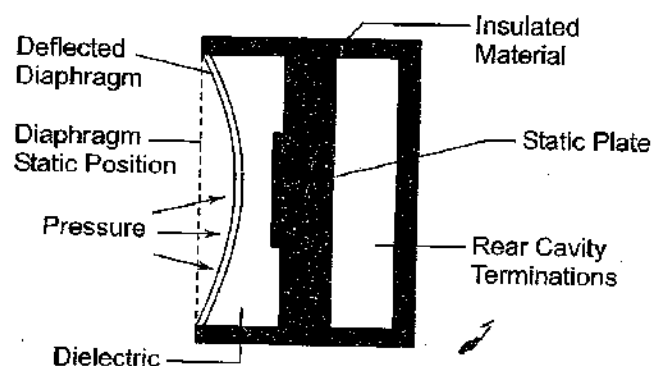

Fig. 13.29 Capacitive Pressure Transducer

Enclosed in an airtight container is a metallic diaphragm which moves to the left when pressure is applied to the chamber and to the right when vacuum is applied. This diaphragm is used as one plate of a variable capacitor. Its distance from the stationary plate to its left, as determined by the pressure applied to the unit, determines the capacitance between the two plates. The monitor indicates the pressure equivalent of the unit's capacitance by measuring the capacitor's reactance to the ac source voltage.

(The portion of the chamber to the left of the moving plate is isolated from the side into which the pressurised gas or vapour is introduced. Hence, the dielectric constant of the unit does not change for different types of pressurised gas or vapour. The capacity is purely a function of the diaphragm position.) This device is not linear.

Changes in pressure may be easily detected by the variation of capacity between a fixed plate and another plate free to move as the pressure changes. The resulting variation follows the basic capacity formula.

$$C = 0.885 \frac{K(n-1)A}{t} \text{ pf} \quad (13.15)$$

where A = area of one side of one plate in cm^2

n = number of plates

t = thickness of dielectric in cm

CHAPTER 8- OSCILLOSCOPE

BASIC PRINCIPLE OF OSCILLOSCOPE.

A CRO (Cathode-Ray Oscilloscope), or DSO (Digital Storage Oscilloscope), is a type of electronic test instrument that allows observation of constantly varying signal voltages, usually as a two-dimensional plot of one or more signals as a function of time.

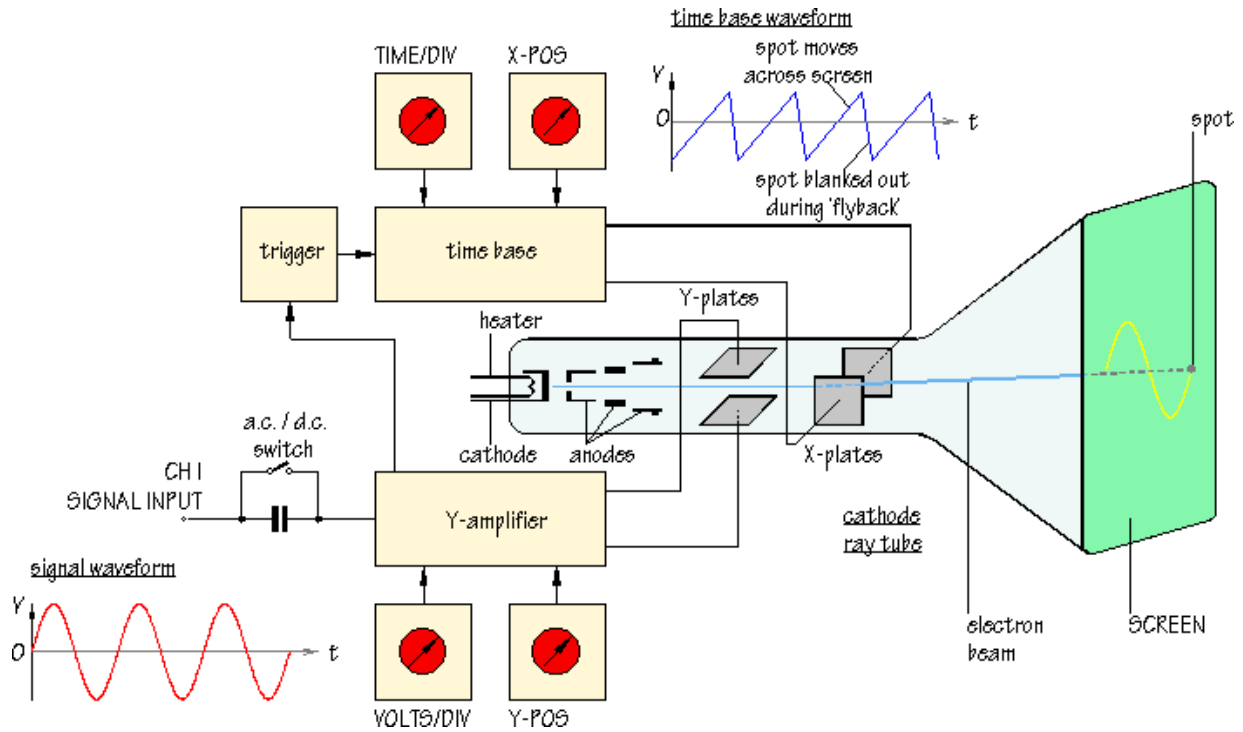

BLOCK DIAGRAM OF OSCILLOSCOPE & SIMPLE CRO.

The block diagram of simple CRO is as shown in figure below. Here the Oscilloscopes are used to observe the change of an electrical signal over time, such that voltage and time describe a shape which is continuously graphed against a calibrated scale. The observed waveform can be analyzed for such properties as amplitude, frequency, rise time, time interval, distortion and others. Modern digital instruments may calculate and display these properties directly. Originally, calculation of these values required manually measuring the waveform against the scales built into the screen of the instrument.

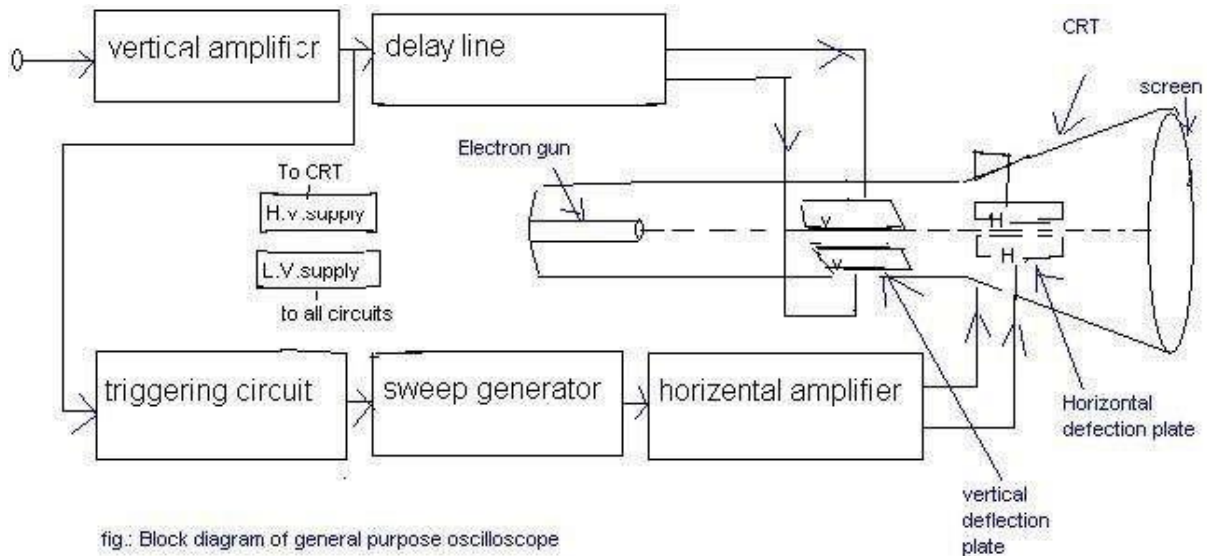

fig.: Block diagram of general purpose oscilloscope

www.ei-notes.blogspot.com

The oscilloscope can be adjusted so that repetitive signals can be observed as a continuous shape on the screen. A storage oscilloscope allows single events to be captured by the instrument and displayed for a relatively long time, allowing human observation of events too fast to be directly perceptible. Oscilloscopes are used in the sciences, medicine, engineering, and telecommunications industry. General-purpose instruments are used for maintenance of electronic equipment and laboratory work. Special-purpose oscilloscopes may be used for such purposes as analyzing an automotive ignition system or to display the waveform of the heartbeat as an electrocardiogram.

DUAL TRACE CRO:

The block diagram of dual trace oscilloscope which consist of following steps,

1. Electronics gun (single)
2. Separate vertical input channels (Two)
3. Attenuators
4. pr-amplifiers
5. Electronic switch.

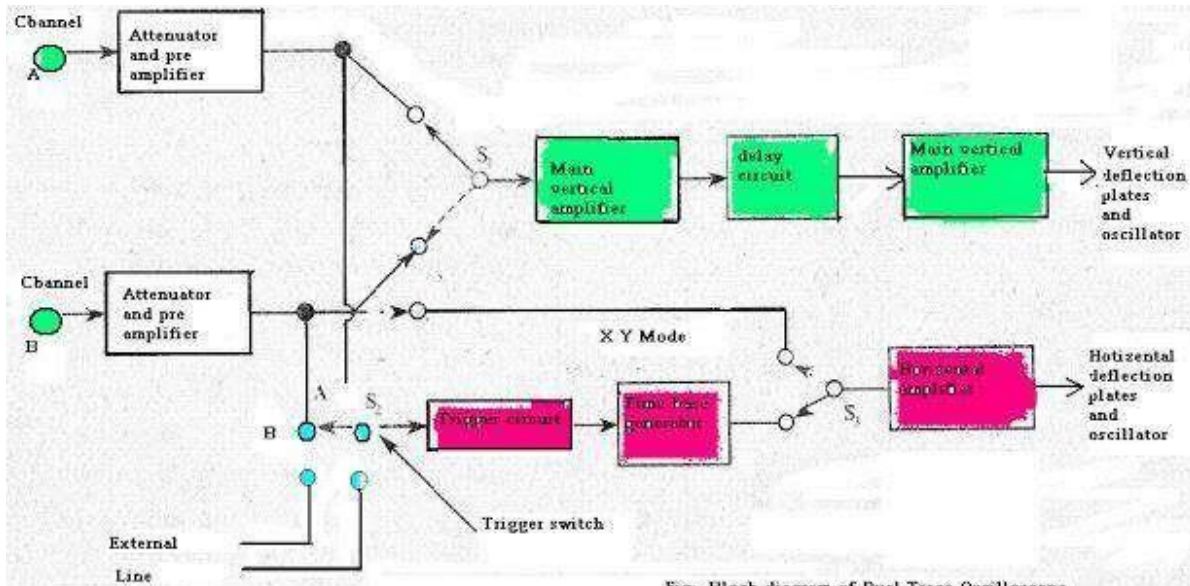

Fig: Block diagram of Dual Trace Oscilloscope

The two separate input signals can be applied to single electron gun with the help of electronic switching it produces a dual trace display. Each separate vertical input channel uses separate attenuators and pre-amplifier stages, so the amplitude of each signal can be independently controlled. Output of the pre-amplifiers is given to the electronic switch, which passes one signal at a time into the main vertical amplifier of the oscilloscope. The time base generator is similar to that of single input oscilloscope. By using switch S_2 the circuit can be triggered on either A or B channel, waveforms, or an external signal, or on line frequency. The horizontal amplifier can be fed from sweep generator or from channel B by switching S_1 . When switch S_1 is in channel B, its oscilloscope operates in the X-Y mode in which channel A acts as the vertical input signal and channel B as the horizontal input signal.

From the front panel several operating modes can be selected for display, like channel B only, channel A only, channels B and A as two traces, and signals $A + B$, $A - B$, $B \sim A$ or $-(A + B)$ as a single trace. Two types of common operating mode are there for the electronic switch, namely,

1. Alternate mode
2. Chop mode.